



**Rules and Regulations for NWH
Versatility Events**

**Version 3.0
January 2011**

TABLE OF CONTENTS

1. GENERAL.....	4
1.1 Horse/Rider Combinations.....	4
1.2 Courses and Patterns.....	4
1.3 Division of Classes.....	4
2. LIFETIME SUPERIOR ACHIEVEMENT PROGRAM.....	4
2.1 Eligibility Requirements.....	4
2.2 LSAP Awards.....	5
2.3 LSAP Points Requirement Summary.....	7
3. MODEL/IN-HAND.....	9
4. SHOWMANSHIP AT HALTER.....	9
4.1 General.....	9
4.2 Tack and Equipment.....	9
4.3 Fitting and Grooming.....	10
4.4 Showing the Horse.....	10
4.5 Additional Tests (as requested by Judge).....	11
4.6 Scoring.....	11
5. BARREL RACING.....	12
5.1 General.....	12
5.2 Tack and Equipment.....	12
5.3 The Pattern.....	12
5.4 Timing.....	13
5.5 Penalties.....	13
5.6 Disqualification.....	13
5.7 Barrel Pattern.....	13
6. COMBINED DRIVING.....	14
6.1 Overall Placement.....	14
7. COMPETITIVE TRAIL RIDING.....	14
7.1 Overall Placement.....	14
8. DRESSAGE.....	15
8.1 General.....	15
8.2 Tests for Dressage Competitions.....	15
8.3 The Gaits of Dressage.....	15
8.4 Objectives and Standards of Levels of Competition.....	16
8.5 Collective Marks.....	17
8.6 Scoring.....	18
8.7 Participation in Dressage Competitions.....	19
8.8 Attire.....	19
8.9 Tack and Equipment.....	19
8.10 Bits Permitted in Dressage.....	20
8.11 Execution of the Tests – Calling Tests.....	20
8.12 Errors.....	20
8.13 General Rules.....	20
8.14 Elimination.....	21
9. ENDURANCE RIDING.....	21
10. EQUITATION.....	22
11. HUNTER OVER FENCES.....	22
11.1 General.....	22
11.2 Course Diagrams and Schooling.....	22
11.3 Obstacles.....	22
11.4 Tack and Equipment.....	23
11.5 Judging.....	23
12. HUNTER HACK.....	24
12.1 General.....	24
12.2 Obstacles.....	24
12.3 Tack, Equipment and Attire.....	25
12.4 Judging.....	25

13. JUDGED PLEASURE RIDES	25
13.1 Overall Placement.....	25
14. OBSTACLE DRIVING.....	26
14.1 General.....	26
14.2 Tack and Equipment.....	26
14.3 Class Procedure.....	26
14.4 Suggestions for Obstacles.....	26
14.5 Judging.....	26
15. PLEASURE DRIVING.....	27
16. POLE BENDING.....	27
16.1 General.....	27
16.2 Tack and Equipment.....	27
16.3 The Pattern.....	28
16.4 Timing.....	28
16.5 Penalties.....	28
16.6 Disqualification.....	28
16.7 Pole Bending Diagram.....	29
17. REINING.....	30
17.1 General.....	30
17.2 Tack and Equipment.....	30
17.3 Scoring.....	30
17.4 Penalties.....	31
17.5 Patterns.....	31
18. REINSMANSHIP.....	43
18.1 General.....	43
18.2 Tack and Equipment.....	43
18.3 Class Procedure.....	43
18.4 Scoring.....	43
18.5 Disqualifications.....	43
19. TRAIL OBSTACLE.....	44
19.1 General.....	44
19.2 Class Specifications.....	44
19.3 Course Design.....	44
19.4 Judging.....	46
19.5 Scoring.....	48
20. WATER GLASS.....	48
20.1 Tack and Equipment.....	48
20.2 General Rules.....	49
20.3 Scoring.....	49
20.4 Disqualification.....	49
21. WESTERN RIDING.....	49
21.1 General.....	49
21.2 Tack and Equipment.....	49
21.3 Scoring.....	50
21.4 Disqualification.....	51
21.5 Accepted Patterns.....	51
21.6 Judge's Score Card.....	56
22. REFERENCES.....	56

1 GENERAL

The National Walking Horse Association (NWA) Rule Book applies in all matters. Many disciplines are addressed there. Please refer to the NWA rule book for complete information regarding shoeing, attire and equipment. The Versatility Program provides a venue for owners to showcase the versatility of the breed in classes other than "Rail". This program recognizes the versatility of the walking horse and its inherent ability to do whatever the rider wishes.

1.1 Horse/Rider Combinations

For any versatility event where competitors ride individually, the horse may enter a maximum of one time with an adult rider AND one time with a youth rider. No horse may be entered with more than one adult rider or more than one youth rider. Riders may enter on multiple horses as time and show management permit.

1.2 Courses and Patterns

For any event that requires a course, pattern, or individual test, that pattern must be posted at least one hour prior to the beginning of the class. Show managers may make courses and patterns available (electronically or printed) prior to the show at their discretion.

1.3 Division of Classes

Classes may be divided into youth and adult where there are sufficient entries. At the show managers' discretion, classes may be divided by experience or difficulty (Examples: green horse, novice rider, advanced, etc.). Show management will determine whether green or junior horses may compete in both green and advanced classes.

2 LIFETIME SUPERIOR ACHIEVEMENT PROGRAM

NWA provides a program that recognizes horses that compete in different types of classes. The Lifetime Superior Achievement Program (LSAP) is designed so that horses and riders may accumulate points and awards for both "rail" classes and "versatility" classes. Each division shall have both Youth and Adult awards, with separate requirements for each.

Awards may be earned for:

- English Pleasure
- Western Pleasure
- Versatility
- Model

2.1 Eligibility Requirements

- Owner must be a NWA member.
- Owner must nominate the horse.
- Points start accumulating when the owner is a NWA member and the horse is nominated.
- Once a horse is nominated, the owner receives a log book into which (s) he enters information regarding the horse's showing record each year.
- Point books must be returned to the office by December 31 of each calendar year.
- Points may be earned at any show (they do not have to be affiliated with NWA), if the show has a licensed judge.

- Adult points will be awarded to the horse.
- Youth points will be awarded to the horse/rider combination.
- When a Youth turns adult, they must re-nominate their horse if they wish to continue accumulating points.
- Points accumulate from year to year. The exception for this accumulation is the Annual Register of Merit, for which the adult-nominated horse or youth horse/rider combination must accumulate points in one calendar year. The points earned for the Register of Merit count toward both the championship and Order of the Equinus Awards.

(2.2 LSAP Awards)

2.2.1 Annual Register of Merit

To earn an annual Register of Merit, a horse nominated by an adult must earn a minimum of twenty points in one versatility, pleasure, or model event during the calendar year. A youth horse and rider combination earns the Annual Register of Merit award after earning fifteen (15) points in any event in one calendar year.

2.2.2 Versatility Championship

To earn a versatility championship, horses must compete in at least five (5) of the versatility events recognized by NWA. Horses nominated by adults must earn at least fifteen (15) points in each of the five events, while youth horse/rider combinations must earn at least ten (10) points in each. To complete the championship, additional points may be accrued in any of the versatility events recognized by NWA. Horses nominated by adults must earn a total of 100 points in versatility events, and youth horse/rider combinations must earn 75 points.

The National Walking Horse Association recognizes the following performance categories for accumulating versatility points in the LSAP:

- Barrel Racing
- Combined Driving
- Competitive Trail Riding
- Dressage
- Endurance Riding
- Equitation (walking seat and stock seat)
- Hunter Over Fences
- Hunter Hack
- Judged Pleasure Riding
- Obstacle Driving
- Pleasure Driving
- Pole Bending
- Reining
- Reinsmanship
- Trail Obstacles
- Water Glass
- Western Riding

2.2.3 English Pleasure Championship

To receive an English Pleasure championship, adult-nominated horses must earn 100 points in English pleasure classes. A minimum of 75 of these points must be accrued in 3-gait (canter) classes. Youth horse/rider combinations must accumulate 75 points in English Pleasure classes, with a minimum of 50 points accrued in canter classes.

The National Walking Horse Association recognizes the following performance categories for accumulating English Pleasure points in the LSAP:

- English Pleasure (canter)
- E-Z Rider English

2.2.4 Western Pleasure Championship

To receive a Western Pleasure championship, adult-nominated horses must earn 100 points in Western pleasure classes. A minimum of 75 of these points must be accrued in 3-gait (canter) classes. Youth horse/rider combinations must accumulate 75 points in Western Pleasure classes, with a minimum of 50 points accrued in canter classes.

The National Walking Horse Association recognizes the following performance categories for accumulating western pleasure points in the LSAP:

- Western Pleasure (canter)
- E-Z Rider Western

2.2.5 Model Championship

To receive a model championship, adult-nominated horses must earn a total of fifty (50) points in Model division classes. At least 40 of these points must be accrued in model classes, while the remaining points may be earned from In-Hand or Showmanship at Halter classes. Youth horse/handler combinations must earn a total of forty (40) points, with thirty (30) of those points accrued in Model classes.

The National Walking Horse Association recognizes the following Model categories for accumulating points in the LSAP:

- Model
- In-Hand
- Showmanship at Halter (Adult and Youth)

2.2.6 Order of the Equinus

Any horse or youth horse/rider combination who earns a versatility championship, pleasure championship (English or western), and model championship is awarded NWAHA's most prestigious honor, the Order of the Equinus (and Youth Order of the Equinus).

2.3 LSAP Points Requirement Summary

Category	General Requirements	Adult Requirements	Youth Requirements
Annual Register of Merit	Points collected in any one versatility, pleasure or model event in one calendar year.	20 Points	15 Points
Model	Points earned in any of the events listed in the category, may be carried year-to-year.	50 total points, 40 must come from Model classes	40 total points, 30 must come from Model classes
English Pleasure	Points earned in English 3-gait pleasure or 2-gait pleasure classes. May be carried year-to-year.	100 total points, 75 must come from canter classes	75 total points, 50 must come from canter classes
Western Pleasure	Points earned in Western 3-gait pleasure or 2-gait pleasure classes. May be carried year-to-year.	100 total points, 75 must come from canter classes	75 total points, 50 must come from canter classes
Versatility	Minimum 5 events. Points carried year-to-year.	100 total points, minimum 5 events with 15 or more points accrued in each event	75 total points, minimum 5 events with 10 or more points accrued in each event



National Walking Horse Association
Lifetime Superior Achievement
Nomination Form

To nominate your horse for this program, print, complete, and mail this nomination form to:

NWHA Lifetime Superior Achievement Program
Kentucky Horse Park
4059 Iron Works Pkwy., Suite 4
Lexington, KY 40511

NWHA Lifetime Superior Achievement Nomination Form

Name of Horse: _____

Breed of Horse: _____

Registration # (if applicable): _____

Name of Owner: _____

Address of Owner: _____

Phone Number of Owner: _____

Name of Rider: _____

Is this nomination for Youth _____ Date of Birth _____

or Adult _____

NWHA
Kentucky Horse Park
4059 Iron Works Pkwy., Suite 4
Lexington, KY 40511
Phone: 859-252-NWHA
Fax: 859-252-0640

3 MODEL/IN-HAND

Complete rules for model and in-hand classes may be found in the NWA Rule Book, Section 4.3, Halter Division; and section 10.24.

4 SHOWMANSHIP AT HALTER

Showmanship is designed to judge the exhibitor's ability to present the horse. The exhibitor uses the horse as a means to display his or her ability to properly fit and show. Exhibitors are judged on the fitting, grooming, training, and showing of their horses.

4.1 General

- Showmanship classes should be divided according to the age of exhibitors.
- The horse's conformation is not to be considered in the judging of the class.
- The horse must be serviceably sound.
- Exhibitors must wear the correct attire for the division in which they are participating.
- Whips are permitted with English attire only.
- Patterns are at the judges' discretion and may be different for different age levels. If a pattern is used the exhibitors must be provided the opportunity to ask questions prior to the start of the class.
- Patterns must be posted at least one hour prior to the beginning of the class.

4.2 Tack and Equipment

The exhibitor shall present a neat, clean, well groomed, attentive, courteous, look that is appropriate for the division. Either Western or English clothes are permitted but they may not be mixed and they must match the tack used on that horse. More elaborate clothes and/or equipment are permitted but not given preference. Suitability of tack and clothes, fit, and cleanliness will be considered. Properly worn ASTM/SEI approved headgear is strongly recommended in any and all events. For complete descriptions of English and Western attire, please refer to the NWA Rule Book Section 8, Attire and Equipment.

Clean and properly adjusted equipment should be used. Lead shanks (or ropes) should be 6-7 feet long. If a chain is used it should be adjusted so that the exhibitors hands do not touch the chain. The shank needs to be short enough to assure maximum control and responsiveness from the horse.

4.2.1 Western

- Leather Halter; chain on lead strap permitted (may be used over or under horse's nose).
- Rope Halters are not permitted.
- Whips of any kind are not permitted.

4.2.2 English

- English-style show halter; chain on lead strap permitted (may be used over or under horse's nose).
- Rope Halters are not permitted.
- Arab-style cable halters are not permitted.

4.3 Fitting and Grooming

The horse shall present a polished appearance. The bridle path should be clipped to approximately 4 inches behind the poll, as well as the long hair on the jaw, pasterns and legs. Manes and tails shall be groomed and clean and free of tangles. Braids are acceptable for English attire, but no braids are permitted on horses showing western. The horse's feet should be trimmed and may be properly shod. The hooves should be clean. Black or clear hoof polish is optional.

4.4 Showing the Horse

Always lead from the left side at an alert walk, following the judge's directions. The length of the lead should not be so short as to interfere with free, natural movement of the animal or so long as to surrender control or permit a sloppy lead. Exhibitors must have the right hand on the lead when leading their horse. The left hand holds the remainder of the lead in one loose loop or figure eight fold. The exhibitor should never hold the chain portion of the lead.

Horses should walk in a brisk, alert manner and give the appearance that the exhibitor and horse are a team.

Any turns requiring more than 90 degrees must be made to the right. Any turns requiring 90 degrees or less should be made to the left.

Posing: Keep the horse posed (square, not parked) at all times, know where the judge is and what they want. Make it easy for the judge to see the horse at its best advantage. Position the horse by the pressure on the lead. When posing the horse, stand toward the front, facing the horse at a 45 degree angle, but never directly in front of the horse. Always be in a position where you can observe your horse and keep an eye on the judge. The Quarter Method is the suggested method of showmanship.

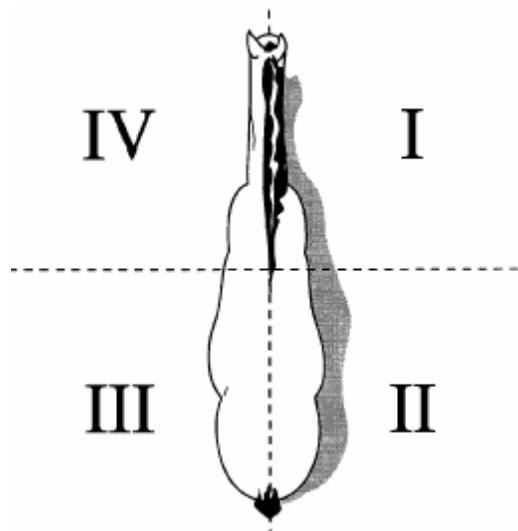

Using the quarter method, when the judge comes to quadrant I, the handler should be in IV. As the judge moves to II, the handler moves to I. When the judge moves to III, the handler moves to IV. As the judge moves up the horse to IV, the handler returns once more to Quadrant I.

4.4.1 Faults

- 1) Allowing the horse to remain out of position
- 2) Standing directly in front of your horse
- 3) Using your feet to move the horse's feet
- 4) Failure of the horse to lead properly
- 5) Failure to stop before turning when showing at a walk and flatwalk
- 6) Failure to back
- 7) Loud voice commands to your horse or other unnecessary actions
- 8) Kicking
- 9) Pushing the horse with your hands or using your hands to place the horse's feet and legs
- 10) Moving to the offside of the horse and remaining out of position
- 11) Not remaining alert and watching the judge for instructions
- 12) Using a tightly coiled lead
- 13) Not using a properly fitted halter
- 14) Holding your hand on the chain of the lead shank
- 15) Failure to glance back and check your horse to see that it is tracking straight with the judge
- 16) Trotting or Pacing

4.5 Additional Tests (as requested by Judge)

- 1) The judge may question exhibitors. The same question must be asked of each exhibitor.
- 2) Walk horse to and from the judge.
- 3) Back the horse.
- 4) Reverse the horse, or turn 90 degrees or 180 degrees.
- 5) Pick up horses hoof or hooves.
- 6) Move to a different spot in line.

4.6 Scoring

- Exhibitor attire and equipment: (20%)
- Horse (fitting and grooming): (30%)
- Exhibitor's method of showing: (50%)

5 BARREL RACING

5.1 General

Barrel Racing is a timed event in which the horse and rider execute a clover-leaf pattern around three barrels. The horse/rider team who completes the pattern in the shortest time wins. In the event of a tie, the tied horse/rider teams have a run off. The fastest time in the run-off is declared the winner of that placing, and the second horse moves to the next lower placing.

5.2 Tack and Equipment

Western attire and equipment is required for barrel racing. Properly worn ASTM/SEI approved headgear is highly recommended for the exhibitor in any and all events and shall not be penalized. All youth riders **MUST** wear ASTM/SEI-approved helmets. Exhibitors must wear a hat or helmet when entering the ring. "Stampede Strings" may be used. Baseball caps ARE NOT permitted. A 5-second penalty will be assessed if the hat or helmet is not on the exhibitor's person the entire time they are in the arena. For complete descriptions of Western tack and attire, please refer to the NWAHA Rule Book Section 8, Attire and Equipment.

- Martingales, tie-downs, protective boots, and polo wraps are permitted in Barrel Racing.
- Hackamores (including mechanical hackamores) and bosals are permitted.
- Whips, crops, or bats are prohibited.
- Draw reins are prohibited.

5.3 The Pattern

The barrel distances for a standard size arena (130 ft. wide by 200 ft. long) are as follows:

- From the starting line the 1st and 2nd barrels is 60 feet.
- The distance *between* the first and second barrels is 90 feet,
- The distance from the 1st and 2nd barrels to the 3rd barrel is 105 feet.

The course must be measured exactly. However, if the course is too large for the available space, the pattern should be reduced five yards at a time until the pattern fits the arena. It is not necessary to move barrel #3 closer to the start/finish line in this case. When measuring the area for the course, allow ample room for the horses to complete their turns and stop at the finish.

Barrels must not be placed within 15 feet of any obstacle. Maintain a distance of at least 18 feet from each barrel to the rail. It is recommended there be at least 45 feet from the starting line to the end of the arena.

55 gallon drums with both ends intact should be used.

Barrel patterns may be run either to the right or left, at the discretion of the exhibitor.

At a signal from the starter, the exhibitor will run to the first barrel, complete an approximate 360 degree turn around it, go to barrel number two, complete an approximately 360 degree turn around it, and then proceed to the last barrel, another approximate 360 degree turn around it, and sprint to the finish line.

In a right-hand pattern, the horse enters in the middle, turns right to go around barrel #1 (near barrel #1 but between barrels #1 and #3), comes across the arena and turns left around barrel number 2 (near barrel #2 but between barrels #2 and #3), and then proceeds through the middle of the arena to turn left again around barrel #3 (going near barrel #3 but between Barrel #3 and Barrel #1) before sprinting to the finish line.

In a left-hand pattern, the horse enters in the middle, turns left to go around barrel #2 (near barrel #2 but between barrels #2 and #3), comes across the arena and turns right around barrel number 1 (near barrel #1 but between barrels #1 and #3), and then proceeds through the middle of the arena to turn right again around barrel #3 (going near barrel #3 but between Barrel #3 and Barrel #2) before sprinting to the finish line.

5.4 Timing

Starting line markers or electric timers (when possible) shall be placed against the arena fence. An electric timer or at least two stop watches shall be used, with the time indicated by the electric timer or an average time of the watches used by the official timers to be the official time.

Timing shall begin as soon as the horse's nose reaches the starting line and will stop when the horse's nose reaches the finish line. The exhibitor is allowed a running start from inside the arena after the gate is closed. Horses shall not be allowed to run out of the arena after the pattern is complete.

5.5 Penalties

- Knocking over a barrel – five (5) seconds. Exhibitors may touch the barrel with their hands to prevent it from tipping.
- Hat or helmet is not on the exhibitor's person for the entire time the exhibitor is in the arena – 5 seconds.

5.6 Disqualification

- Failure to follow the course
- Use of illegal tack or equipment
- Using the ends of the reins to whip the horse
- Fall of horse or rider
- Breaking the time barrier prior to completing the course or breaking the barrier a second time after completing the course

5.7 Barrel pattern

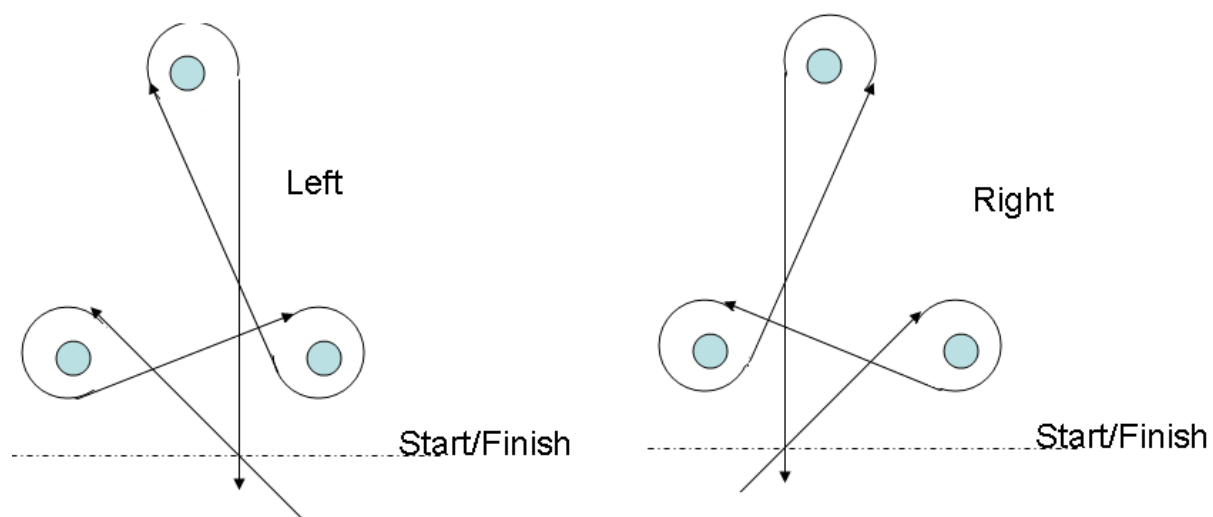

*Reproduced with permission of the American Quarter Horse Association

6 COMBINED DRIVING

Combined driving combines three separate phases, one on each day, similar to 3-day eventing. Each phase tests the ability of the horse and driver. First, dressage tests the balance, flexibility and communication skills of the pair. Next, the marathon event tests the horse's endurance and stamina over a cross-country course driving through obstacles. Finally, the "cones" test calls for precision driving between sets of cones laid out in an elaborate course.

The general rules and requirements of the sanctioning body of the competition will apply.

Each LSAP-registered walking horse competing in a combined driving event shall receive points as follows:

6.1 Overall Placement

Calculated the same as all other LSAP points.

6.1.1 First place LSAP horse

5 points (if there are more than 7 horses in the division). If there are less than 7 horses in the division, points will be calculated the same as other LSAP points.

6.1.2 Second place LSAP horse

3 points (if there are more than 5 horses in the division). If there are less than 7 horses in the division, points will be calculated the same as other LSAP points.

6.1.3 Third place LSAP horse 1 point

7 COMPETITIVE TRAIL RIDING

In competitive trail riding, the horse is judged on condition, soundness and trail ability on natural trail obstacles. The rider is judged on presentation, grooming (no artificial enhancements, polished hooves, etc.), trail equitation, trail safety/courtesy, stabling, etc. The general rules and requirements of the sanctioning body of the competition will apply.

Each LSAP-registered walking horse competing in competitive trail riding shall receive points as follows:

7.1 Overall Placement

Calculated the same as all other LSAP points.

7.1.1 First place LSAP horse

5 points (if there are more than 7 horses in the division). If there are less than 7 horses in the division, points will be calculated the same as other LSAP points.

7.1.2 Second place LSAP horse

3 points (if there are more than 5 horses in the division). If there are less than 7 horses in the division, points will be calculated the same as other LSAP points.

7.1.3 Third place LSAP horse 1 point

8 DRESSAGE

8.1 General

Dressage is the development of communication between the horse and rider. We strive for a calm, supple, confident, and attentive horse. Eventually, the horse achieves perfect understanding with its rider.

The objectives are shown in the following attributes::

- The freedom and regularity of the gaits
- The harmony, lightness, and ease of movement
- The lightness of the forehand, engagement of the hindquarters
- Acceptance of the bit

8.2 Tests for Dressage Competitions

Current NWA dressage tests are provided online at www.nwha.com.

(8.3 The Gaits of Dressage)

8.3.1 The Medium Walk

The medium walk is a marching pace in "four time". Often, in the world of the gaited horse, the slow (normal horse) walk is referred to as a dog walk. In no case should the medium walk be "dog-like". Rather, it is an energetic, marching gait. The horse is soft and giving through the poll and jaw, listening to the aids, and has its hind end engaged. The horse should use its back and exhibit some overstride. Remember, the name of this gait is the **medium** walk.

8.3.2 Free Walk

At the free walk, the horse is allowed to lower and stretch out its head and neck. At this forward moving gait, the horse stretches forward and downward over its top line in search of contact. One does not throw away the reins, but rather allows the horse to take them as he stretches. The horse must be able to listen to seat and legs for guidance and to maintain straightness. The free walk is often performed on the diagonal, which is the longest possible straight line in the arena. Steering with the hands is penalized.

8.3.3 Flat Walk/ Running Walk

The flat walk is a four-beat marching pace with a regular rhythm. The flat walk, should be moved into without hesitation. The flatwalk is clearly a different gait from the medium walk, just as the trot is a clearly different gait in non-gaited dressage. Horses who do not exhibit a clear intermediate gait must be severely penalized.

The running walk is an extension of the flat walk, and will be discussed in section 8.4.3.

8.3.4 The Canter

The canter is a three-beat gait. In example, at canter to the right, the footfalls follow: left hind, simultaneous left fore and right hind, right fore, and then followed by a moment of suspension with all four feet in the air. The canter should be light, and regular. Transitions to the canter should be quiet and without hesitation.

Often, gaited horses exhibit a gait which is not a true canter. These horses will usually canter with their front legs, but will do something entirely different behind. This disunion must be penalized. Additionally, a 4-beat canter is extremely undesirable and must be penalized as well.

(8.4 Objectives and Standards of Levels of Competition)

8.4.1 INTRODUCTORY LEVEL

Introductory level will determine that the horse is willing to learn and is quiet and supple in its gaits. The horse should move forward with a steady rhythm, and should begin to accept contact with the bit. The tests are performed at the medium walk and the flat walk. The horse should move forward at both gaits. He should accept the guidance of the rider happily and quietly, changing gaits without resistance. He should present a balanced, relaxed frame, but he need not be “on the bit” yet. He should bend through its circles and corners, and travel straight on the straight lines. At this level, he need not have attained true collection.

When the horse halts at the end of the test, he may halt from the flatwalk through the walk, but again, this transition should be made quietly and without resistance. At the medium walk, he should march forward with purpose. If the test calls for a free walk, he should stretch forward and downward, seeking contact with the bit. At the flatwalk, the horse must exhibit a true flatwalk, evenly spaced in 4-time. Failure to show a true intermediate gait must be severely penalized.

At the Introductory level, the horse is asked to exhibit the medium walk, the flatwalk, the free walk, and the halt. The movements required are changes of rein across the diagonal, straight lines, and 20-meter circles.

8.4.2 TRAINING LEVEL

Training level confirms that the horse can move forward freely with a steady rhythm, accepting contact with the bit. At training level, the horse must exhibit all of the qualities of an introductory level horse, and more. At training level, the horse has learned to use its hind end to create impulsion, which comes through and over its back and into the bridle. Its poll and jaw are soft and giving. He exhibits balance and forwardness at all gaits. Lack of impulsion at this level should be penalized more heavily than at the intro level. The halt should be square and prompt, with little walking between the flatwalk and the actual stop. The medium walk should be swinging, with a little overstride. The flatwalk must be true, with the hind legs driving through. The canter is 3-beat, balanced, and quiet. Exhibition of a 4-beat canter, cross canter, or any other not-true canter shall be heavily penalized. Transitions should be made without resistance (e.g. the horse bracing, raising the head, etc.). The position of the horse’s head and neck at training level more closely resembles that of a dressage horse, but he is not yet ready for true collection.

8.4.3 FIRST LEVEL

“The First-Level horse, in addition to the requirements of Training level, has developed thrust (pushing power) and achieved a degree of balance and thoroughness.”

At the first level, the horse begins to exhibit true collection. He is soft in the jaw and poll, carries through from behind, and uses its rounded back properly to carry himself and its rider. The horse’s head should be slightly IN FRONT of vertical; any over-flexing is considered resistance and should be penalized.

At first level, the horse and rider exhibit lengthening of stride. This lengthening, or extension, is what transforms the flatwalk into the running walk. At the running walk, the horse steps farther under himself with its back legs and reaches. The tempo of the foot fall should not change, but the amount of ground covered per stride will, so the speed will increase. The running walk is not truly a different gait from the flatwalk, but rather an extension.

By the time a horse achieves first level, lightness, balance and harmony are apparent.

At the first level, we ask the horse to maintain its balance as we decrease the diameter of the circles. It is asked to change its balance from one direction to the other as it traverses the width of the area, and finally, to exhibit the leg yield.

8.4.4 SECOND LEVEL

The Second-Level horse now shows that through additional training it accepts more weight on the hind quarters (collection), and is reliably on the bit. More straightness, bending, suppleness, throughness, and self-carriage is required than at First Level.

At Second level, the horse demonstrates its increasing education and understanding of leg and seat aids by demonstrating the shoulder in, travers, and counter-canter. Canter circle diameters decrease to 10 meters.

8.4.5 THIRD LEVEL

The Third-Level horse demonstrates, especially in medium and extended gaits and in the transitions to and from collected movements:

- Rhythm
- Suppleness
- Acceptance of the bit
- Throughness
- Impulsion
- Straightness
- Collection
-

There must be a clear distinction between the gaits.

8.5 Collective Marks

At the end of each test, the judge awards the collective marks. These marks are the general overall impressions in each of the following categories:

- a. Gaits
- b. Impulsion
- c. Submission
- d. The rider's position and seat

The collective marks generally carry a “coefficient”, or multiplier. The multiplier serves to add weight to these marks. Using the collective marks, the judge provides an overall impression of the exhibitor’s ride. An example of the scoring of collective marks follows:

COLLECTIVE MARKS:

GAITS: Freedom and regularity.	2
IMPULSION: Desire to move forward, elasticity of the steps, suppleness of the back, engagement of the hindquarters.	2
SUBMISSION: Attention and confidence, harmony, lightness and ease of movements, acceptance of the bridle, lightness of the forehand.	2
RIDER: Position and seat, correctness and effect of the aids.	3

8.5.1 GAITS

The judge takes into account the overall quality of ALL the gaits exhibited. No one gait receives preferences over the other. If the horse exhibits an excellent flatwalk, but less than average canter, the collective mark must take both into account. The judge should review the individual scores and comments of the test’s movements to arrive at his or her final collective mark for gaits.

8.5.2 SUBMISSION

This mark provides an overall impression of the horse's willingness to relax the jaw, flex over the poll, and submit to the rider's aids. A horse that presents a tense, hollow frame will receive a significantly lower score than one who is soft and giving.

8.5.3 IMPULSION

This mark reflects the overall ability of the horse to use its hind end as a motor to propel himself forward. The horse must shift its balance rearward and use its hind legs to push its body forward. This energy should transmit all the way from the back legs through the bridle as the horse moves forward.

At the medium walk, the horse demonstrates impulsion with a marching, forward cadence. At the flatwalk, the horse propels himself by driving from behind. Similarly, at the canter, the horse presents a balanced frame with its hind legs reaching well under its body. Impulsion is never a gauge of speed.

8.5.4 POSITION OF RIDER

The aids of the hands, legs, and seat are of great importance in dressage. The judge provides an overall assessment of the rider's ability to communicate with the horse, the effectiveness of the aids, and the correctness of the overall position of the rider on the horse. The rider should present a balanced position, with the shoulder, hip, and heel in a straight line close to perpendicular with the horizon. The rider's loins and hips remain supple, thighs and legs steady and well stretched downward. The rider should not grip with the knee or any other part of the leg, but rather allow the weight of the leg to flow downward from the hip through the heel. The upper body should be upright and relaxed. Elbows must be bent so that the rider's arms fall naturally from the shoulder along the body, and then bend to meet the reins. Hands are carried slightly above the horse's withers, about 4" to 6" apart, with the thumbs on top and the wrists straight. Reins may be held between the 4th finger and the pinky, or outside the pinky. Both hands must be the same height above the withers.

The rider should apply the aids promptly and correctly, demonstrating the proper use of seat, legs, and hands. Simultaneously, the horse must respond to the aids. Failure to do so indicates a lack of training or concentration.

8.6 Scoring

All movements and certain transitions are scored individually on the judge's sheets. They are marked 0 to 10, 0 being the lowest mark and 10 being the highest.

The scale of marks follows:

10 Excellent	4 Insufficient
9 Very Good	3 Fairly Bad
8 Good	2 Bad
7 Fairly good	1 Very Bad
6 Satisfactory	0 Not Executed
5 Sufficient	

"Not Executed" means that practically nothing of the required movement has been performed.

After each performance, the judge's sheets are scored. The marks are multiplied by the corresponding coefficients where applicable, and then totaled. Penalty points incurred for errors in the execution of the test are then deducted on each judge's sheet. The total number of points earned is then divided by the total number of possible points and multiplied by 100 to arrive at a percentage. The rider with the highest percentage wins the class.

8.7 Participation in Dressage Competitions

Dressage competitions are open to all riders and all horses over 36 months of age. Stallions may not be ridden by riders under 18 years of age. No horse may be ridden more than once in any dressage class.

Horses may enter no more than two consecutive levels at any one competition. For example, a competitor may ride Intro and Training level, or Training and First levels, but may not ride Intro and First nor all three.

A dressage competition manager may not compete at his or her own competition. However, he or she may ride "Hors de Concours" (receives score, but it is not counted for awards) if they wish.

8.8 Attire

The dress for gaited dressage competition is any English attire. Exhibitors may choose to wear:

- Traditional Dressage attire: (dressage style jacket, shirt and stock tie or choker, breeches, tall boots, and hunt cap or derby hat)
- Hunt seat attire (hunt coat, shirt and stock tie or choker, breeches, tall boots, hunt cap)
- Traditional saddleseat attire (long coat, shirt and tie, jodpurs and jodpur boots, derby or top hat)
- Gloves are optional

Exhibitors are encouraged to wear protective ASTM/SEI-approved headgear. Such protective headgear should be black or be covered with a dark hat cover.

A whip no longer than 4' including lash may be carried in all classes.

Spurs must be made of metal, and there must be a shank pointing directly back from the center of the spur. The arms of the spur must be smooth. If rowels are used, they must be free to rotate.

8.9 Tack and Equipment

An English type saddle with stirrups is compulsory at all levels. Cut-back saddles are allowed if the horse is exhibited in saddle seat attire.

For level one and two tests, a plain snaffle bit must be used. Third-level and above tests, may be ridden in a double bridle.

The following equipment is forbidden:

- Martingales
- Bit guards
- Any kind of gadgets (bearing, side, running, balancing reins, tongue tied down, etc.)
- Boots or bandages
- Blinkers
- Ear muffs or plugs, nose covers
- Seat covers
- Hoods
- Ribbons, flowers, etc. in the mane or tail (except for braided ribbon of the type worn in English Pleasure, if the horse is presented in saddle seat attire)

Use of any of the above equipment will result in the elimination of the competitor.

A breastplate and/or crupper may be used. Braiding of the horse's mane and tail is encouraged.

Ring stewards spot-check saddlery either before the horse enters or immediately it leaves the arena. The responsibility for the correct attire and equipment rests with the competitor.

8.10 Bits Permitted in Dressage

Snaffle bits are required through second level. All bits must be smooth and solid. Twisted, wire, and roller bits are prohibited. The following snaffle bits are permitted:

- a) Ordinary snaffle with single- or double-jointed mouth piece
- b) Racing (D-ring) snaffle
- c) Full-cheek snaffle
- d) Egg-butt snaffle
- e) snaffle with upper or lower cheeks
- f) Unjointed (mullen-mouth) snaffle
- g) Dr. Bristol
- h) Fulmer
- i) French snaffle
- j) Certain "level 1" Myler bits with no leverage action
- k) Baucher single- or double-jointed bit

8.11 Execution of the Tests - Calling Tests

The exhibitor may have any tests called during the competition except at any Dressage Show final or Dressage championship event at which time all tests must be ridden from memory. If tests are called, it is the responsibility of the competitor to arrange for a person to announce the test. Lateness and errors in announcing will not relieve the rider from error penalties."

8.12 Errors

When a competitor makes an "error of the course" (takes the wrong turn, omits a movement, etc), the judge will alert the rider by using a bell or other sound. The judge will then tell the competitor where s/he went off, the point at which they must take up the test again, and the next movement to be executed. The judge then allows the competitor to continue.

Errors are penalized:

- a. 1st error: 2 points
- b. 2nd error: 4 points
- c. 3rd error: 8 points
- d. 4th error: Elimination. The competitor may continue their ride, and receive marks for them, but they will not be considered for placing.

(8.13 General Rules)

8.13.1 Lameness

In the case of marked lameness or soreness, the horse and rider are eliminated. There is no appeal against this decision.

8.13.2 Accuracy

In a movement which must be carried out at a certain point of the arena, it should occur at the moment when the competitor's body is above this point. Accuracy should be a factor only if the inaccuracy makes the movement easier. If a problem appears once, it may be treated lightly; if it appears multiple times, the judge will score it more harshly each time.

8.13.3 Grinding of the teeth and wringing of the tail

Both are signs of tenseness or resistance and will be noted in the score where they appear and in the collective marks. Having the tongue over the bit or performing with an open mouth are also signs of resistance and the judge will mark it down.

8.13.4 Fall of horse and/or rider

If the horse or rider falls, the competitor will not be eliminated. He will be penalized by the effect of the fall on the movement being performed and also in the collective marks.

8.13.5 Unusual Circumstances

The judge may stop a test and/or allow a competitor to restart a test from the beginning or from any appropriate point in the test if, in his or her discretion, some unusual circumstance has occurred to interrupt the test.

8.14 Elimination

The following will result in eliminations:

- a. Misrepresentation of entry or inappropriate entry
- b. Illegal equipment
- c. Unauthorized assistance
- d. Four errors of the course
- e. Horse's tongue tied down
- f. Late entry into the arena
- g. All four feet of the horse leave the arena
- h. Cruelty
- i. Marked lameness or soreness
- j. Resistance of longer than 20 seconds
- k. Any situation where a direct rule violation can be cited

9 ENDURANCE RIDING

Endurance rides are a minimum of 25 miles in length, and the first horse/rider team who completes the ride wins. The general rules and requirements of the sanctioning body of the competition will apply.

Each LSAP-registered walking horse competing in an endurance ride shall receive points as follows:

9.1.1 Overall Placement

Calculated the same as all other LSAP points.

9.1.2 First place LSAP horse

5 points (if there are more than 7 horses in the division). If there are less than 7 horses in the division, points will be calculated the same as other LSAP points.

9.1.3 Second place LSAP horse

3 points (if there are more than 5 horses in the division). If there are less than 7 horses in the division, points will be calculated the same as other LSAP points.

9.1.4 Third place LSAP horse 1 point

9.1.5 Completion of a ride of over 100 miles 3 points

9.1.6 Completion of a ride 50-100 miles 1 point

9.1.7 Best Conditioned of Ride 5 points

10 EQUITATION

Complete rules for all types of equitation (walking seat and stock seat) classes may be found in the NWA Rule Book, 4.4, Equitation Division; and section 10.25 – 10.26.

11 HUNTER OVER FENCES

11.1 General

The Over Fences classes are judged on performance, soundness, suitability and manners. Horses perform over a minimum of seven obstacles at a controlled, even hunter pace. Excessive speed is not desirable and shall be penalized. Judges are responsible for correctness of each course and shall call the show committee's attention to any errors that would tend to result in unfair or inappropriate courses. **ALL EXHIBITORS MUST WEAR AN ASTM/SEI-APPROVED HELMET during any and all schooling and while showing over fences.**

11.2 Course Diagrams and Schooling

The course diagram will show the obstacles in the order indicated by numbers. An arrow is used on the diagram to indicate the direction which each obstacle is to be taken. Schooling fences must be provided by show management, which may include the opportunity to school the actual course prior to the beginning of the class. If riders are not allowed to school the actual course, they must have the opportunity to walk the course prior to the start of the class.

11.3 Obstacles

The course shall include a minimum of four (4) actual jumps. At least one change of direction is mandatory. Obstacles must be at least 2 feet (2') and a maximum of three feet (3') in height. At Championship shows, fences will be set at a minimum of 2'6" and a maximum of 3'6". Show management may add a "green hunter" (horses in their first or second year showing over fences) class where fences shall be 2 feet to 2'6" at championship shows and 18" to 2'6" at non-championship shows. Obstacles must simulate those found in the hunting field such as natural post and rail, brush, stone wall, white board fence or gate, chicken coop, aiken, hedge, oxer, etc.

"Jumper" type fences such as liverpools, banks, hogs backs, targets are prohibited. Additionally, spreads over four feet and square oxers are prohibited.

A ground line is required for all obstacles. Courses shall be designed so as to provide smooth turns and lines. Sharp roll-backs, "jumper" style turns and challenges are prohibited.

11.3.1 In-And-Outs

An in-and-out is a pair of jumping efforts set either one or two strides apart. They are considered as one obstacle in the required number of obstacles, and must never be used as the first fence. The suggested distance for a one-stride in-and-out is 20' to 24'. The distance between fences for a 2- stride in-and-out should be 30 to 36 feet.

(11.4 Tack and Equipment)

11.4.1 Tack

English bridles with snaffles, pelhams or kimberwicks are required. Figure eight nosebands are prohibited. Saddles must be a jumping saddle (close contact, all-purpose or eventing) or dressage saddle. Cut back saddles are prohibited.

11.4.2 Equipment

Protective boots, wraps and bandages are permitted. Martingales are permitted, but must be adjusted so as to be safe. Tie-downs and draw reins are not permitted in jumping classes. Hunterstyle crops, not to exceed 3 feet in length, are permitted.

11.4.3 Attire

Exhibitors should wear traditional English hunt seat attire, including:

- ASTM/SEI-approved hunt cap or helmet (**REQUIRED**)
- “Ratcatcher” or collared, button-down shirt
- Stock tie or choker
- Hunt seat or dressage style jacket
- Breeches or jodhpurs
- Hunt seat “dress” or “field” boots. Jodphur boots and matching half-chaps are permitted in non-championship classes.
- Youth riders may exhibit in jodphurs, jodphur boots and garters.

It is recommended that long manes be put up in a “running braid” to prevent the rider’s hands from becoming tangled.

(11.5 Judging)

11.5.1 Soundness

Horses that are not serviceably sound will be excused by the judge and are ineligible for placing.

11.5.2 Performance

The horse should exhibit a quiet, even-paced canter, exceptional manners, and good jumping style. These attributes combine with faults and way of moving over the course. Excessive speed must be penalized. The performance starts as the competitor enters and ends when he leaves.

11.5.3 Faults

The following faults are scored according to the judge’s opinion, and depending on severity, may be considered minor or major faults.

Minor or Major Faults:

- Showing an obstacle to a horse.
- Not changing leads when required
- Spooking.
- Inappropriate jumping form

11.5.4 Suggested Scoring

Scoring shall be on a basis of 0-100 with a break-down of:

- 90-100- Excellent performer
- 80-89 - Good or excellent performer that may commit one or two minor faults
- 70-79 - Fair mover, no severe faults, good performer with a few minor faults
- 60-69 - Poor mover, minor mistakes, average mover 1 or 2 poor fences
- 50-59 - Horse commits one major fault; refusal, crow canter, drops legs, hind-end knockdown
- 30-39 - Two or more major faults, dangerous manor
- 10-29 - Horse avoids elimination but jumps unsafely

Major Faults

- Knocking down an obstacle.
- Refusals.
- Breaking gait.
- Bucking.
- Stopping for broken equipment.
- Circling while on course.
- Dangerous jumping.

Elimination

- Three refusals.
- Off course.
- Jumping a fence before it is reset. Riders will not be penalized for stopping to wait for a fence to be reset.
- Bolt ing.
- Stopping for loss of shoe.
- Fall of horse or rider.

The following may or may not be considered as faults:

- Light rubs
- Late lead changes
- Excessive animation

When a horse makes two faults at one obstacle only the major fault will be counted. Refusals count in addition to a major fault. For an In-and Out, each obstacle is considered separately. In case of a refusal or runout at one obstacle in a combination, the competitor must re-jump the entire combination. Judges must penalize unsafe jumping and bad form over fences, whether touched or untouched. Circling once upon entering the ring and once upon leaving is recommended. In cases of broken equipment, the competitor may either continue without penalty or stop and fix the problem, in which case he will be penalized. In case of loss of shoe, rider may either continue without penalty or choose to stop and be eliminated. Schooling is not allowed in the event of elimination.

12 HUNTER HACK

12.1 General

Hunter Hacks will be judged on style over fences, quiet, even canter, flat work, manners and way of going.

12.2 Obstacles

Horses are required to jump two fences between eighteen inches (18") and two (2') feet. A ground line is required for each jump. Horses also work both directions on the rail at a medium walk, intermediate gait and canter. Horses jump individually but work on the rail as a group. The judge may decide whether to have the exhibitors work on the rail first or do the jumping work first. Generally, all exhibitors line up in the center of the ring during the individual jumping portion of the class.

12.3 Tack, Equipment and Attire

Tack, equipment and attire are identical to that of the Hunter over Fences, with one exception.

Exhibitors may wear traditional English saddle seat or English hunt seat attire.

ASTM-approved hunt caps or helmets are required for ALL exhibitors both for schooling and exhibiting over fences.

12.4 Judging

Horses are judged on way of going and suitability for the hunt field. Horses should exhibit a calm forward motion. Excessive speed shall be penalized. Excessive pulling of the reins shall also be penalized. At the discretion of the judge, contestants may be asked to hand gallop, stop, or back and stand quietly. The class shall be judged with 70% emphasis for individual fence work and 30% for work on the flat.

Faults over fences will be scored as in Working Hunter. Faults (to be scored accordingly, but not necessarily cause disqualification during rail work) include:

- (1) Wrong lead
- (2) Excessive speed at any gait
- (3) Breaking gait

13 JUDGED PLEASURE RIDES

Judged pleasure rides are not timed, except that riders might have a time limit on any particular obstacle. Helmet use is recommended and encouraged. Horse/rider teams may use any type of saddle and bridle (including hackamores and bosals). Riders are judged on how well they negotiate their horse through the obstacles with an emphasis on calmness and safety. Judged pleasure rides are not a race. Judged Pleasure rides are also called Trail Trials.

Obstacles are natural and typically encountered while on a trail ride. A judge at each obstacle evaluates the way both horse and rider negotiate these obstacles. The general rules and requirements of the sanctioning body of the competition will apply.

Each LSAP-registered walking horse competing in a trail trial shall receive points as follows:

13.1.1 Overall Placement

Calculated the same as all other LSAP points.

13.1.2 First place LSAP horse

5 points (if there are more than 7 horses in the division). If there are less than 7 horses in the division, points will be calculated the same as other LSAP points.

13.1.3 Second place LSAP horse

3 points (if there are more than 5 horses in the division). If there are less than 7 horses in the division, points will be calculated the same as other LSAP points.

13.1.4 Third place LSAP horse 1 point

14 OBSTACLE DRIVING

14.1 General

This class tests the skill of the driver, the obedience and handiness of the horse, and the accuracy with which the course is driven. Judging is based on performance, manner, and appropriateness of entry.

Breeching or thimbles or securely adjusted wraps are required since a number of obstacles require entrants to back. Obstacles will be at least 16" wider than the width of the vehicle, measured hub to hub.

General driving rules may be found in the NWA Rule Book, Section 10.21.

14.2 Tack and Equipment

Complete driving appointments may be found in the NWA Rule Book, 10.21.

14.3 Class Procedure

Competitors may have the opportunity to walk the course prior to the start of the class, but no horse may enter the ring, either in hand, under saddle, or hitched, prior to its turn to compete. Competitors drive over a course consisting of six (6) to eight (8) obstacles. The course will be irregular, necessitating changes of direction. Markers indicating obstacles will be at least 16 inches wider than the outside hub of the wheels of each vehicle and at least 12 inches high. (Traffic cones with tennis balls on top work well). Obstacles that are not combined must be at least fifteen (15) feet from one another.

If open, all-breed, driving classes are offered and gaits other than a dog-walk are posted in the pattern, the words "working walk" may be used in place of "walk" and "intermediate gait" or "pleasure gait" may be used in place of "flatwalk."

Leading a turnout into the ring is considered outside assistance and not permitted. Drivers receiving outside assistance after the judging has begun will be disqualified.

14.4 Suggestions for Obstacles

- a. bridge - must be at least 8' wide
- b. back into a stall, touch bar, drive out; or back between two cones and touch a third
- c. walk with wheels between triple rails - right two rails 16" apart (10" at more advanced level)
- d. drive through an L
- e. u-turn with center cone
- f. Figure 8 between cones - cones minimum 30' apart
- g. twist between 3 to 5 cones minimum 25' apart
- h. drive beside a distracting but reasonable trail type object
- i. navigate between 2 pairs of cones making a 10' square

14.5 Judging

The purpose of the competition is to test the skill of the driver and the obedience and handiness of the animal. The obstacle driving shall be scored 80% on a fault system and 20% on manners, responsiveness, and smoothness of performance. Credit shall be awarded to horses that negotiate the course in a continuous motion, smoothly and alertly, in prompt response to the driver's cues.

14.5.1 Faults

- First and second refusal. A refusal is defined as a horse refusing to move forward to the obstacle or backing away from the obstacle. The horse may stop for a moment and then proceed without penalty, but ANY backward step will count as a refusal.
- Touching or Displacing marker
- Hoof or wheel outside marker
- Breaking gait
- Showing an obstacle to the horse

14.5.2 Elimination

- Three accumulated refusals
- Receiving outside assistance
- Runaways shall be eliminated immediately
- Taking an obstacle out of order (off course). “Off course” is defined as taking an obstacle in the wrong direction, negotiating from the wrong side, skipping a task (unless directed by the judge), or negotiating obstacles in the wrong order.
- Equipment failure, including breakage of either harness or vehicle which necessitates a halt for repair. Management or a technical delegate may insist on a safety inspection of the vehicle before allowing it to be used in subsequent classes.
- An overturned vehicle

15 PLEASURE DRIVING

Complete rules for pleasure driving classes may be found in the NWA Rule Book, Section 10.21.

16 POLE BENDING

16.1 General

Pole Bending is a timed event in which the horse and rider execute a serpentine pattern around six poles spaced twenty-one (21) feet apart. The horse/rider team who completes the pattern in the fastest time wins. In the event of a tie, the tied horse/rider teams have a run off. The fastest time in the run-off is declared the winner of that placing, and the second horse moves to the next lower placing.

16.2 Tack and Equipment

Western attire and equipment is required for pole bending. Properly worn ASTM/SEI approved headgear is highly recommended for the exhibitor in any and all events and shall not be penalized. Youth riders **MUST** wear ASTM/SEI-approved safety helmets. Exhibitors must wear a hat or helmet when entering the ring. “Stampede Strings” are permitted. Baseball caps ARE NOT permitted. A 5-second penalty will be assessed if the hat or helmet is not on the exhibitor’s person the entire time they are in the arena. For complete descriptions of Western tack and attire, please refer to the NWA Rule Book Section 8, Attire and Equipment.

- Whips, crops, or bats are prohibited.
- Martingales, tie-downs, protective boots, and polo wraps are permitted.
- Hackamores (including mechanical and non-mechanical) and bosals are permitted.

16.3 The Pattern

The poles must be placed in a straight line, with 21 feet between each pole and 21 feet from the first pole to the start/finish line. The course must be measured exactly. Assure that the distance between the last pole and the end of the arena is at least 30 feet to allow ample room for the horses to complete their turns.

16.4 Timing

Starting line markers or electric timers shall be placed against the arena fence. An electric timer or at least two stop watches shall be used. The official time is the time indicated by the electric timer or an average time of the watches used. The start/finish line must be clearly marked.

Timing begins when the horse's nose reaches the starting line and stops when the horse's nose reaches the finish line. The exhibitor is allowed a running start from inside the arena after the gate is closed. Horses shall not be allowed to run out of the arena after the pattern is complete.

Pole bending patterns may be run either to the right or left, at the discretion of the exhibitor. At a signal from the starter, the exhibitor will run to the last pole at the far end of the arena, complete an approximate 180 degree turn around it. The competitor then serpentine through the poles, alternating left and right. When the competitor gets to the first pole, they complete an approximate 180 degree turn around it, and serpentine back through the poles to the far end of the arena. After the last pole, the competitor turns 180 degrees toward "home", and sprints to the finish line.

16.5 Penalties

- Knocking over a pole – five (5) seconds.
- A Contestant may touch a pole with his or her hand. If original course is altered by a rider intentionally grasping a pole then a five second penalty will be assessed.
- Hat or helmet is not on the exhibitor's person for the entire time the exhibitor is in the arena – 5 seconds.

16.6 Disqualification

- Failure to follow the course
- Use of illegal tack or equipment
- Using the ends of the reins to whip the horse
- Fall of horse or rider
- Breaking the time barrier prior to completing the course or breaking the barrier a second time after completing the course

16.7 Pole Bending Diagram

*Reproduced with permission of the American Quarter Horse Association

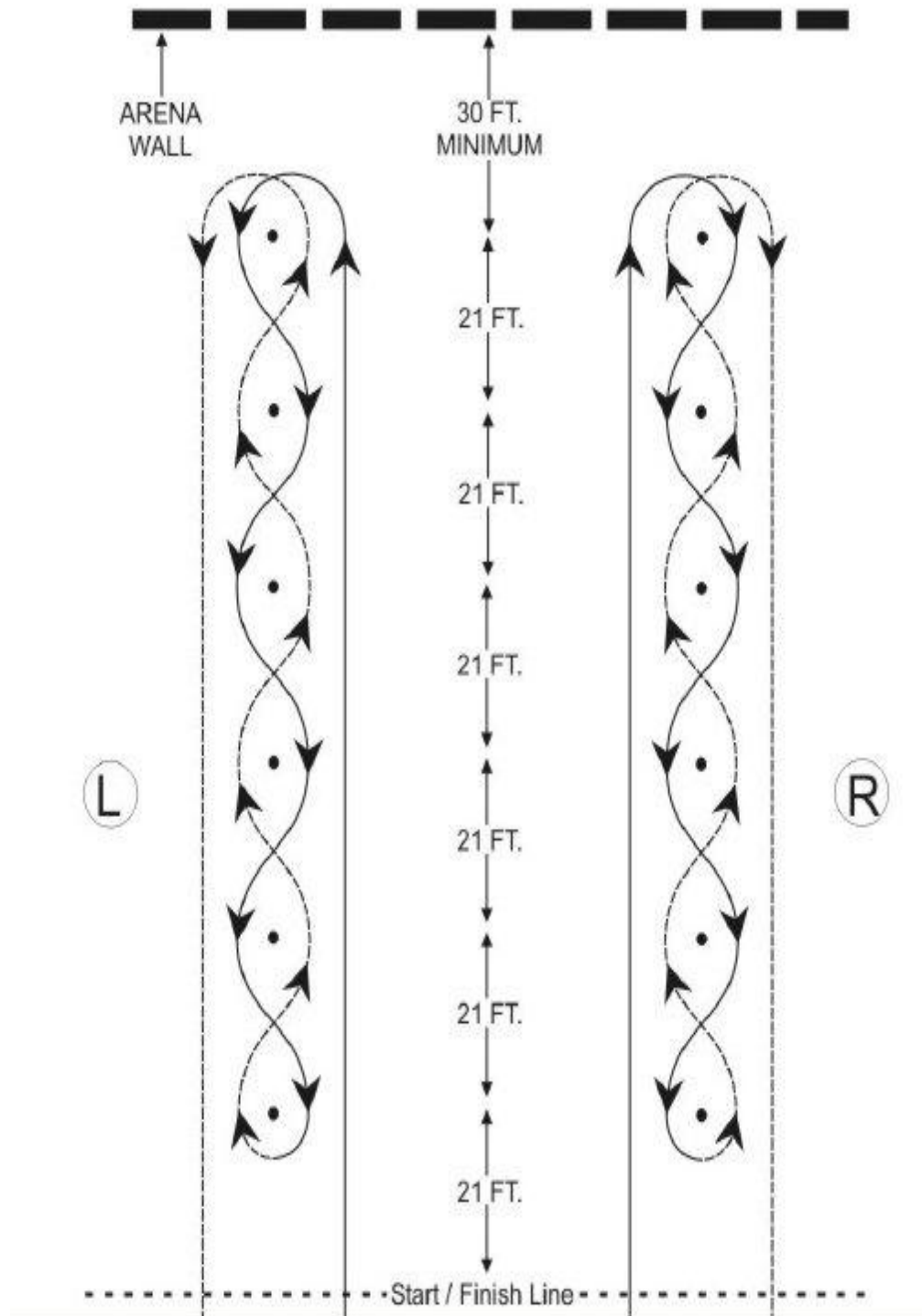

17 REINING

17.1 General

In reining, a horse and rider work as a team to demonstrate the qualities of a working horse. The guidance of the horse should appear effortless, with no apparent resistance. All deviations from the pattern are considered loss of control, and will be scored accordingly.

17.2 Tack and Equipment

Riders must use appropriate western tack and attire. For complete descriptions of Western tack and attire, please refer to the NWHHA Rule Book Section 8, Attire and Equipment. Properly worn ASTM/SEI approved headgear is highly recommended for the exhibitor in any and all events and shall not be penalized. Youth riders **MUST** wear ASTM/SEI-approved safety helmets. Failure to use appropriate attire will result in a final score of zero.

- A curb bit is considered a standard western bit. Use of gag bits is not allowed. Mechanical hackamores are not permitted. Western bosals are permitted only on junior horses.
- Except for junior horses in snaffle bridles or bosal, only one hand may be used on the reins and the rider may not change hands. References to bosal means the use of a flexible, braided rawhide, leather or rope bosal, the core of which may be either rawhide or flexible cable. No rigid material will be allowed under the jaws regardless of how padded or covered. Horse hair bosals are prohibited.
- Protective boots and polo wraps are permitted.
- Whips, crops, or bats are prohibited.
- Tie-downs, martingales and draw reins are prohibited.

17.3 Scoring

The rider begins with a score of 70. The judge scores each movement in 1/2 point increments from a low of -1 1/2 to a high of +1 1/2 with a score of 0 representing a correctly-executed movement with no degree of difficulty.

The following will result in disqualification:

- a. Abuse of an animal
- b. Illegal equipment
- c. Exhibitor disrespect or misconduct
- d. Any unsafe act

The following will result in a final score of 0:

- a. Improper holding of the reins
- b. Off-course
- c. Equipment failure
- d. Balking or refusal
- e. Running away
- f. Fall by horse or rider..
- g. Dropping a rein while the horse is moving
- h. Maneuvers not specified, including turning more than 90 degrees and backing more than 2 strides

If an exhibitor is assigned a score of zero, they are included in the group considered for awards. That is, if there are fewer horses in the class than there are placings, an exhibitor assigned a "0" score may be awarded a ribbon. Disqualified exhibitors must not receive any award, no matter the number of entries.

17.4 Penalties

- Wrong lead -1 point. Add 1 penalty point for each 1/4 of the circumference of a circle or any part thereof out of lead
- Delayed change of lead -1 point penalty from one stride to 1/4 of circumference of a circle, cumulative beyond that point
- Starting circle at a flatwalk or exiting rollbacks at any gait other than canter up to 2 strides – ½ point
- Flatwalk beyond 2 strides but less than ½ circle or 1/2 the length of the arena - 2 points
- Over- or under-spinning up to one-eighth of a turn – ½ point
- Over- or under-spinning up to 1/4 of a turn – 1 point
- Failure to remain a minimum of 20 feet from wall or fence when approaching a stop and/or rollback – ½ point
- Break of gait – 2 points
- Freezing up in spins or rollbacks – 2 points
- Failure to pass the specified marker before initiating a stop – 2 points

The judge shall have the authority to remove any contestant who shows any disrespect or misconduct as to render himself or the competition in an unprofessional manner.

17.5 Patterns

The following patterns are to be worked as stated, not as drawn. Exhibitors who do not complete the pattern AS WRITTEN shall be “off course”, and shall be disqualified.

Markers will be placed on the wall or fence of the arena as follows:

- a. at the center of the arena
- b. at least 50' from each end wall

Where the Pattern designates a stop beyond a marker, the horse should begin its stop after he passes the specified marker.

All horses will be judged immediately upon entering the arena and judging will cease after the last maneuver. Any fault incurred prior to the commencement of a pattern will be scored accordingly. At the discretion of show management, reining patterns may be included on the show's class sheet or program, and may be distributed prior to the show.

*Reining Patterns are reproduced with the permission of the National Reining Horse Association. (See pages 32-42)

REINING PATTERN NUMBER 1

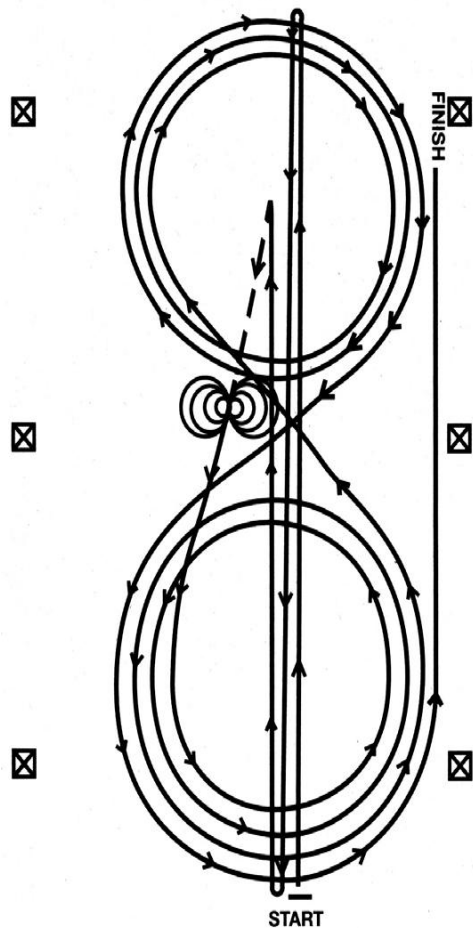

1. Run at speed to the far end of the arena past the end marker and do a left rollback - no hesitation.
 2. Run to the opposite end of the arena past the end marker and do a right rollback - no hesitation.
 3. Run past the center marker and do a sliding stop. Back up to center of the arena or at least ten feet (3 meters). Hesitate.
 4. Complete four spins to the right. Hesitate
 5. Complete four and one-quarter spins to the left so that horse is facing left wall or fence. Hesitate.
 6. Beginning on the left lead, complete three circles to the left: the first circle large and fast; the second circle small and slow, the third large and fast. Change leads at the center of the arena.
 7. Complete three circles to the right: the first circle large and fast, the second small and slow; the third large and fast. Change leads at the center of the arena.
 8. Begin a large fast circle to the left but do not close this circle. Run straight up the right side of the arena past the center marker and do a sliding stop at least 20 feet (6 meters) from wall or fence. Hesitate to demonstrate the completion of the pattern.
- Rider may drop bridle to the designated judge.

REINING PATTERN NUMBER 2

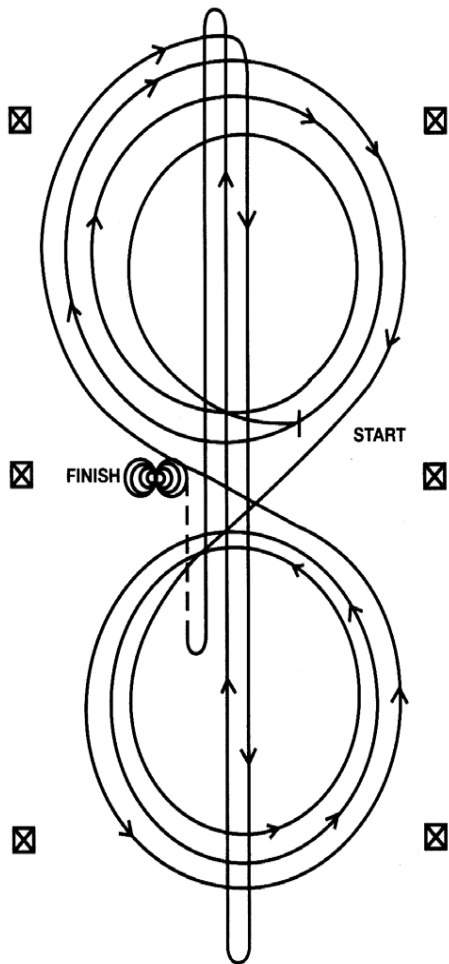

Horse may walk or flat walk to center of the arena. Horse must walk or stop prior to starting pattern. Beginning at the center of the arena facing the left wall or fence.

1. Beginning on the right lead, complete three circles to the right: the first circle small and slow; the next two circles large and fast. Change leads at the center of the arena.
2. Complete three circles to the left: the first circle small and slow; the next two circles large and fast. Change leads at the center of the arena.
3. Continue around previous circle to the right. At the top of the circle, run down the middle to the far end of the arena past the end marker and do a right rollback - no hesitation.
4. Run up the middle to the opposite end of the arena past the end marker and do a left rollback - no hesitation.
5. Run past the center marker and do a sliding stop. Back up to the center of the arena or at least 10 feet (3 meters). Hesitate.
6. Complete four spins to the right.
7. Complete four spins to the left. Hesitate to demonstrate the completion of the pattern

Rider may drop bridle to the designated judge.

REINING PATTERN NUMBER 3

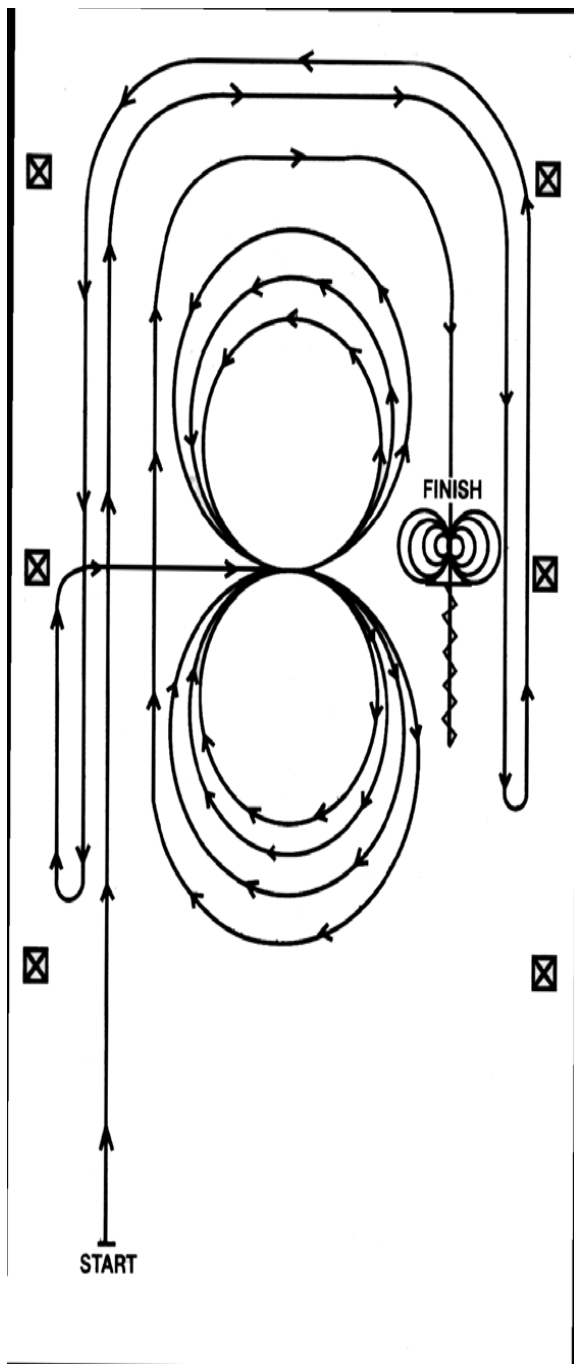

1. Beginning, and staying at least 20 feet (6 meters) from the walls or fence, lope straight up the left side of the arena, circle the top end of the arena, run straight down the opposite or right side of the arena past the center marker and do a left rollback - no hesitation.

2. Continue straight up the right side of the arena staying at least 20 feet (6 meters) from the wall or fence, circle back around the top of the arena, run straight down the left side of the arena past the center marker and do a right rollback - no hesitation.

3. Continue up the left side of the arena to the center marker. At the center marker, the horse should be on the right lead. Guide the horse to the center of the arena on the right lead and complete three circles to the right: the first two circles large and fast; the third circle small and slow. Change leads at the center of the arena.

4. Complete three circles to the left: the first two circles large and fast; the third circle small and slow. Change leads in the center of the arena.

5. Begin a large fast circle to the right but do not close this circle. Continue up the left side of the arena staying at least 20 feet (6 meters) from the wall or fence, circle the top of the arena, run straight down the opposite or right side of the arena past the center marker and do a sliding stop. Back up at least 10 feet (3 meters). Hesitate.

6. Complete four spins to the right. Hesitate.

7. Complete four spins to the left. Hesitate to demonstrate completion of the pattern.

Rider may drop bridle to the designated judge.

REINING PATTERN NUMBER 4

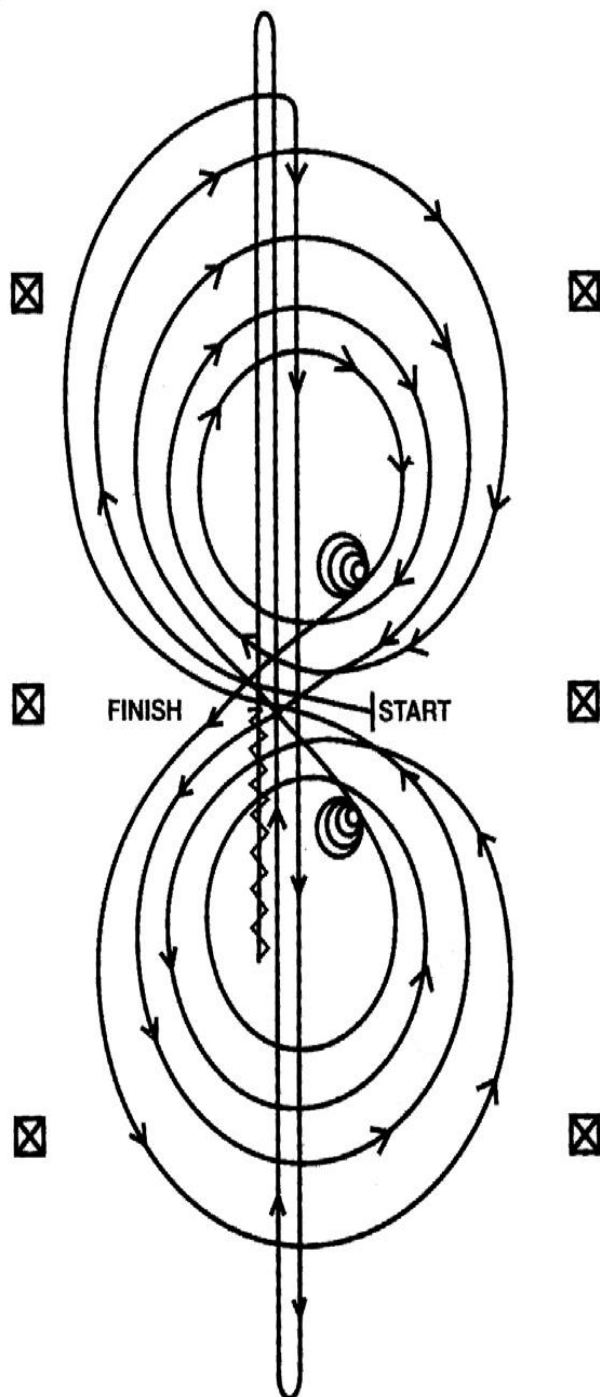

Horse may walk or flatwalk to the center of the arena. Horse must walk or stop prior to starting pattern. Beginning at the center of the arena facing the left wall or fence.

1. Beginning on the right lead, complete three circles to the right: the first two circles large and fast; the third circle small and slow. Stop at the center of the arena.
2. Complete four spins to the right. Hesitate.
3. Beginning on the left lead, complete three circles to the left: the first two circles large and fast; the third circle small and slow. Stop at the center of the arena.
4. Complete four spins to the left. Hesitate.
5. Beginning on the right lead, run a large fast circle to the right, change leads at the center of the arena, run a large fast circle to the left, and change leads at the center of the arena.
6. Continue around previous circle to the right. At the top of the circle, run down the middle to the far end of the arena past the end marker and do a right rollback – no hesitation.
7. Run up the middle to the opposite end of the arena past the end marker and do a left rollback - no hesitation.
8. Run past the center marker and do a sliding stop. Back up to the center of the arena or at least 10 feet (3 meters). Hesitate to demonstrate completion of the pattern.

Rider may drop bridle to the designated judge.

REINING PATTERN NUMBER 5

Horse may walk or flatwalk to the center of the arena. Horse must walk or stop prior to starting pattern. Beginning at the center of the arena facing the left wall or fence.

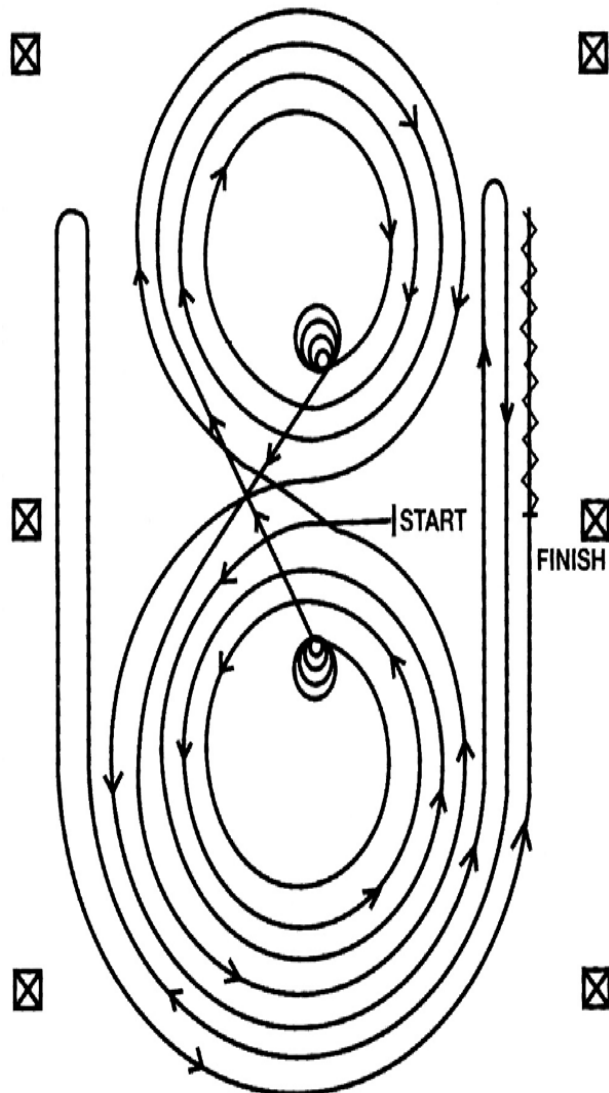

1. Beginning on the left lead, complete three circles to the left: the first two circles large and fast; the third circle small and slow. Stop at the center of the arena.

2. Complete four spins to the left. Hesitate.

3. Beginning on the right lead, complete three circles to the right: the first two circles large and fast; the third circle small and slow. Stop at the center of the arena.

4. Complete four spins to the right. Hesitate.

5. Beginning on the left lead, run a large fast circle to the left, change leads at the center of the arena, run a large fast circle to the right, and change leads at the center of the arena.

6. Continue around previous circle to the left but do not close this circle. Run up the right side of the arena past the center marker and do a right rollback at least 20 feet (6 meters) from the wall or fence – no hesitation.

7. Continue around previous circle but do not close this circle. Run up the left side of the arena past the center marker and do a left rollback at least 20 feet (6 meters) from the wall or fence - no hesitation.

8. Continue back around previous circle but do not close this circle. Run up the right side of the arena past the center marker and do a sliding stop at least 20 feet (6 meters) from the wall or fence. Back up at least 10 feet (3 meters). Hesitate to demonstrate completion of the pattern.

Rider may drop bridle to the designated judge.

REINING PATTERN NUMBER 6

Horse may walk or flatwalk to the center of the arena. Horse must walk or stop prior to starting pattern. Beginning at the center of the arena facing the left wall or fence.

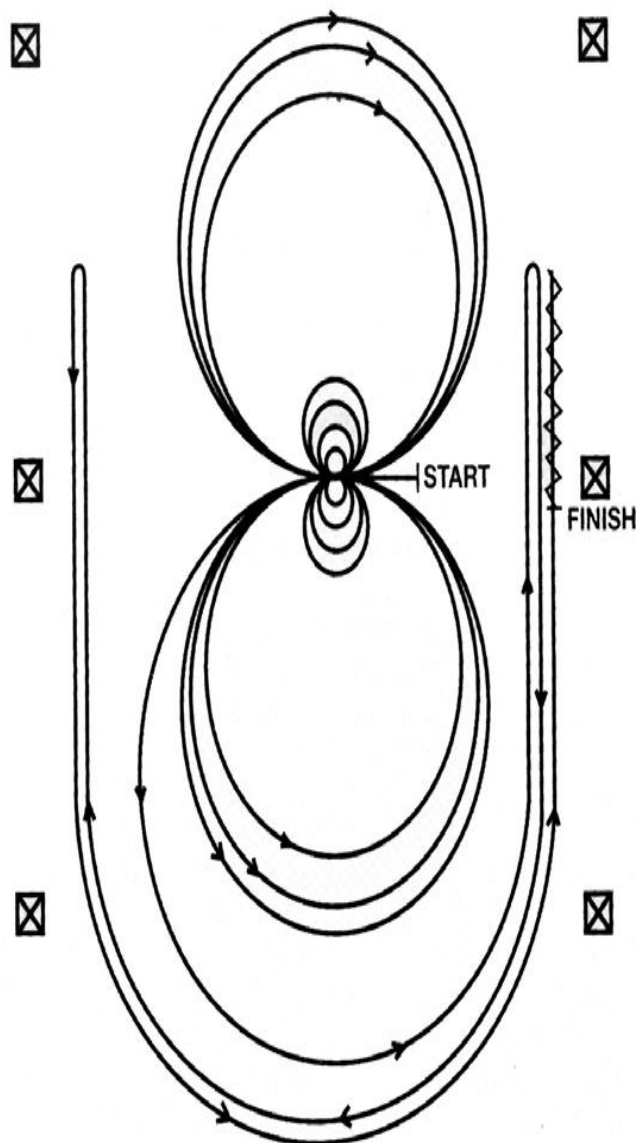

1. Complete four spins to the right. Hesitate.
2. Complete four spins to the left. Hesitate.
3. Beginning on the left lead, complete three circles to the left: the first two circles large and fast; the third circle small and slow. Change leads at the center of the arena.
4. Complete three circles to the right: the first two circles large and fast; the third circle small and slow. Change leads at the center of the arena.
5. Begin a large fast circle to the left but do not close this circle. Run up the right side of the arena past the center marker and do a right rollback at least 20 feet (6 meters) from the wall or fence – no hesitation.
6. Continue back around previous circle but do not close this circle. Run up the left side of the arena past the center marker and do a left rollback at least 20 feet (6 meters) from the wall or fence – no hesitation.
7. Continue back around previous circle but do not close this circle. Run up the right side of the arena past the center marker and do a sliding stop at least 20 feet (6 meters) from the wall or fence. Back up at least 10 feet (3 meters). Hesitate to demonstrate the completion of the pattern.

Rider may drop bridle to the designated judge.

REINING PATTERN NUMBER 7

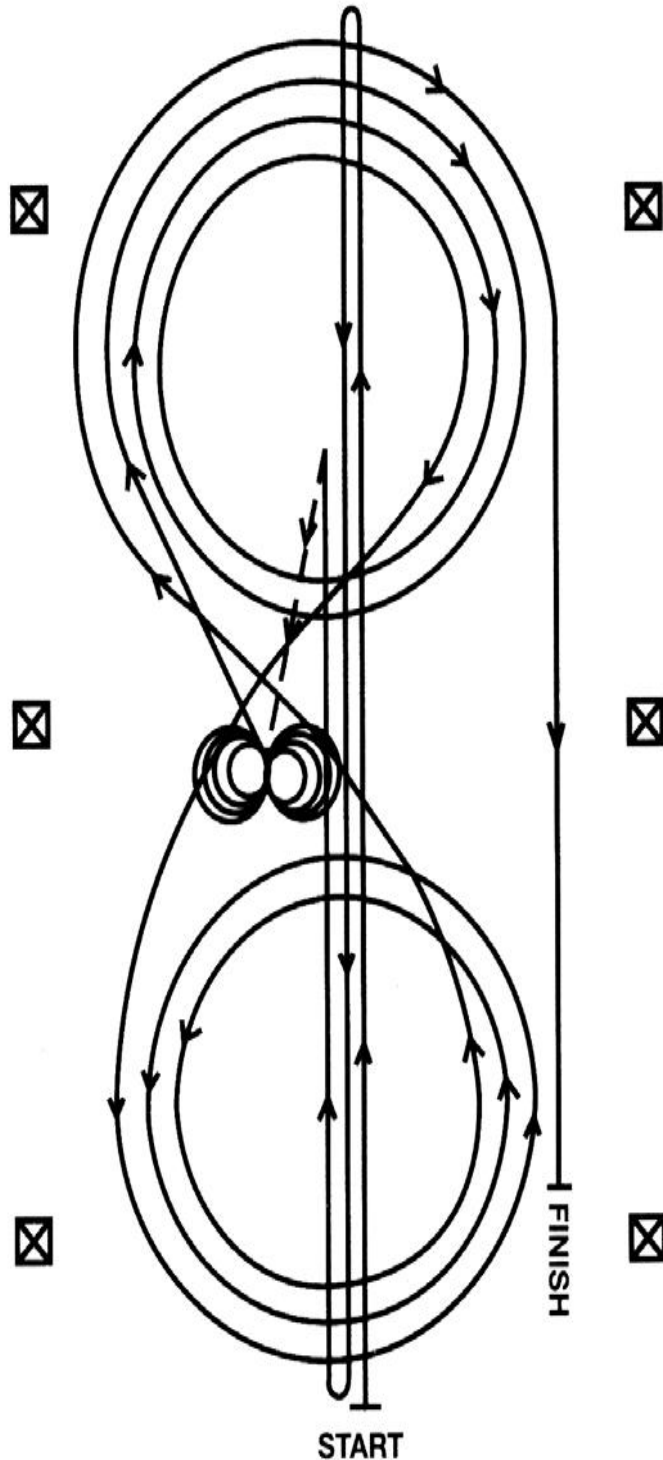

1. Run at speed to the far end of the arena past the end marker and do a left rollback - no hesitation.

2. Run to the opposite end of the arena past the end marker and do a right rollback - no hesitation.

3. Run past the center marker and do a sliding stop. Back up to the center of the arena or at least ten feet (3 meters). Hesitate.

4. Complete four spins to the right. Hesitate.

5. Complete four and one-quarter spins to the left so that horse is facing left wall or fence. Hesitate.

6. Beginning on the right lead, complete three circles to the right: the first two circles large and fast; the third circle small and slow. Change leads at the center of the arena.

7. Complete three circles to the left: the first two circles large and fast; the third circle small and slow. Change leads at the center of the arena.

8. Begin a large fast circle to the right but do not close this circle. Run straight down the right side of the arena past the center marker and do a sliding stop at least 20 feet (6 meters) from the wall or fence. Hesitate to demonstrate completion of the pattern.

Rider may drop bridle to the designated judge.

REINING PATTERN NUMBER 8

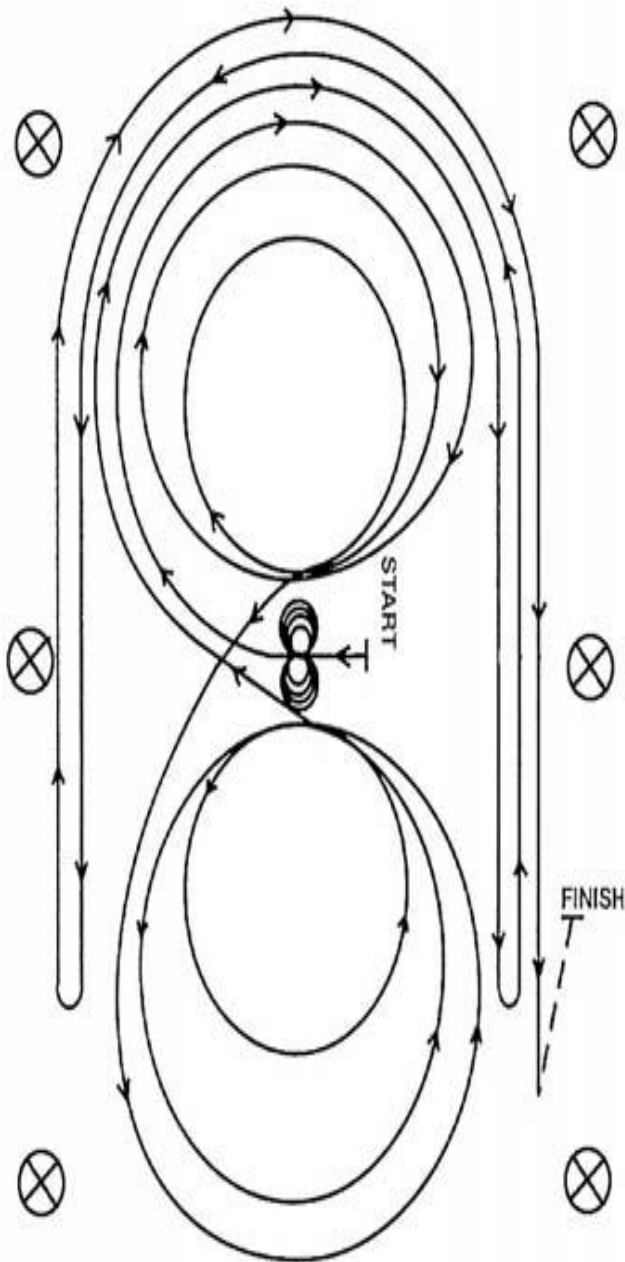

Horse may walk or flat walk to the center of the arena. Horse must walk or stop prior to starting pattern. Beginning at the center of the arena facing the left wall or fence.

1. Complete four spins to the left. Hesitate.
2. Complete four spins to the right. Hesitate.
3. Beginning on the right lead, complete three circles to the right: the first circle large and fast; the second circle small and slow, the third circle large and fast. Change leads at the center of the arena.
4. Complete three circles to the left: the first circle large and fast; the second circle small and slow, the third circle large and fast. Change leads at the center of the arena.
5. Begin a large fast circle to the right but do not close this circle. Run straight down the right side of the arena past the center marker and do a left roll back at least 20 feet (6 meters) from the wall or fence – no hesitation.
6. Continue back around the previous circle but do not close this circle. Run straight down the left side of the arena past the center marker and do a right roll back at least 20 feet (6 meters) from the wall or fence – no hesitation.
7. Continue back around the previous circle but do not close this circle. Run straight down the right side of the arena past the center marker and do a sliding stop at least 20 feet (6 meters) from the wall or fence. Back up at least 10 feet (3 meters). Hesitate to demonstrate completion of the pattern.

Rider may drop bridle to the designated judge.

REINING PATTERN NUMBER 9

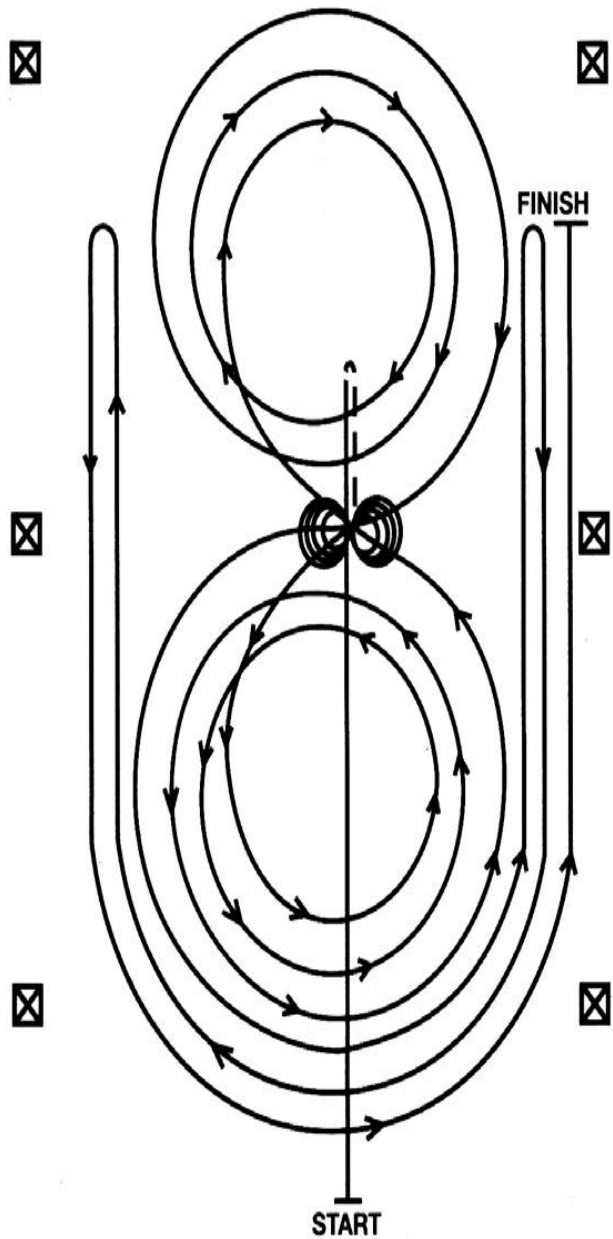

1. Run past the center marker and do a sliding stop. Back up to the center of the arena or at least ten feet (three meters). Hesitate.

2. Complete four spins to the right. Hesitate.

3. Complete four and one-quarter spins to the left so that horse is facing the left wall or fence. Hesitate.

4. Beginning on the left lead, complete three circles to the left: the first circle small and slow; the next two circles large and fast. Change leads at the center of the arena.

5. Complete three circles to the right: the first circle small and slow; the next two circles large and fast. Change leads at the center of the arena.

6. Begin a large fast circle to the left but do not close this circle. Run up the right side of the arena past the center marker and do a right rollback at least twenty feet (six meters) from the wall or fence – no hesitation.

7. Continue back around the previous circle but do not close this circle. Run up the left side of the arena past the center marker and do a left rollback at least twenty feet (six meters) from the wall or fence – no hesitation.

8. Continue back around previous circle but do not close this circle. Run up right side of the arena past the center marker and do a sliding stop at least twenty feet (six meters) from the wall or fence. Hesitate to demonstrate completion of the pattern.

Rider may drop bridle to the designated judge.

REINING PATTERN NUMBER 10

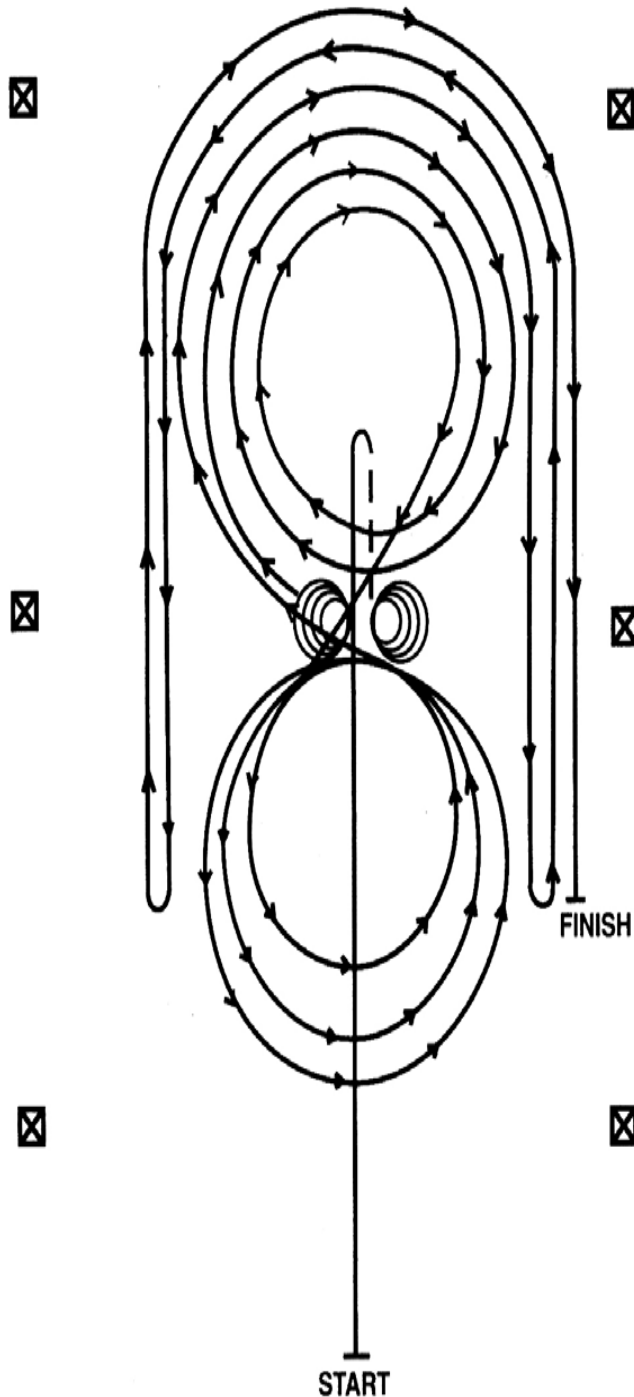

1. Run past the center marker and do a sliding stop. Back up to the center of the arena or at least ten feet (three meters). Hesitate.

2. Complete four spins to the right. Hesitate.

3. Complete four and one-quarter spins to the left so that the horse is facing the left wall or fence. Hesitate.

4. Beginning on the right lead, complete three circles to the right: the first two circles large and fast, the third circle small and slow. Change leads at the center of the arena.

5. Complete three circles to the left: the first circle small and slow, the next two circles large and fast. Change leads at the center of the arena.

6. Begin a large fast circle to the right but do not close this circle. Run down the right side of the arena past the center marker and do a left rollback at least twenty feet (six meters) from the wall or fence – no hesitation.

7. Continue back around the previous circle but do not close this circle. Run down the left side of the arena past the center and do a right rollback at least twenty feet (six meters) from the wall or fence – no hesitation.

8. Continue back around previous circle but do not close this circle. Run down the right side of the arena past the center marker and do a sliding stop at least twenty feet (six meters) from the wall or fence. Hesitate to demonstrate completion of the pattern.

Rider may drop bridle to the designated judge.

REINING PATTERN NUMBER 11 – Green Horse/ Youth Pattern

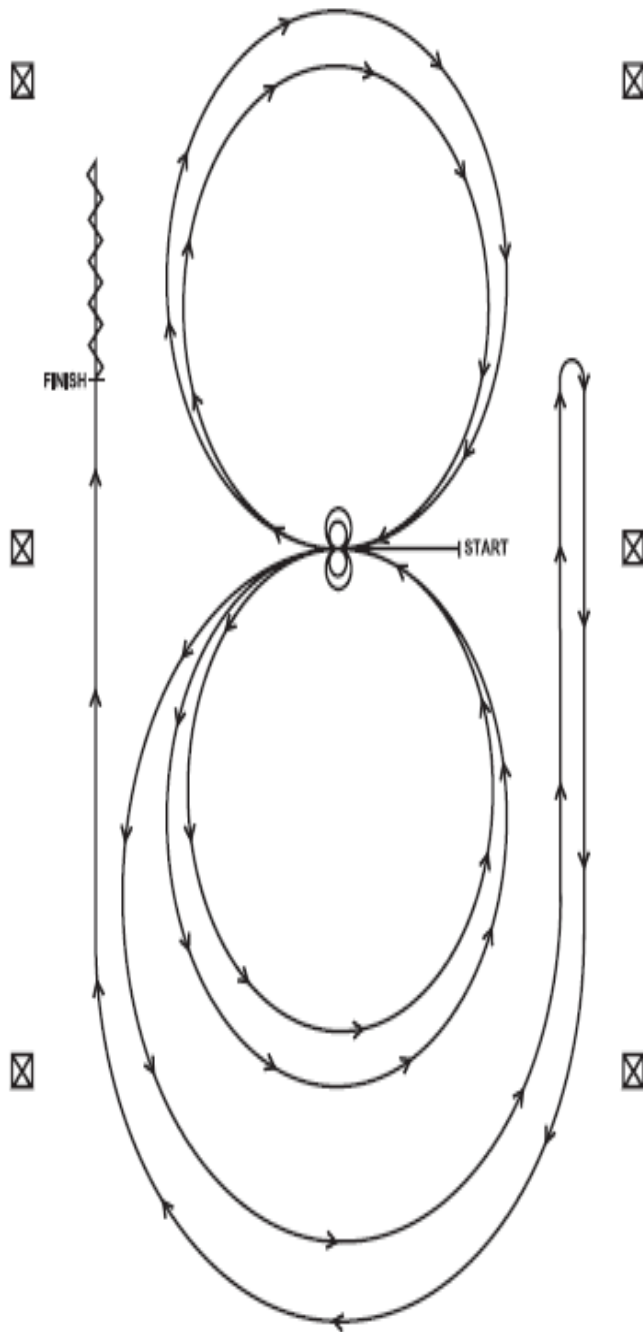

Horses may walk or flatwalk to the center of the arena. Horses must walk or stop prior to starting the pattern. Beginning at the center of the arena facing the left wall or fence.

1. Beginning on the left lead, complete two circles to the left. Stop at the center of the arena. Hesitate.
2. Complete two spins to the left. Hesitate.
3. Beginning on the right lead complete two circles to the right. Stop at the center of the arena. Hesitate.
4. Complete two spins to the right. Hesitate.
5. Beginning on the left lead, go around the end of the arena, run down the right side of the arena past center marker, stop and roll back right.
6. Continue around the end of the arena to run down the left side of the arena past the center marker. Stop. Back up.

Rider may drop bridle to the designated judge.

18 REINSMANSHIP

18.1 General

Reinsmanship is a pleasure driving class in which entries are judged primarily on the knowledge, ability, and skill of the driver and the communication between driver and horse. Horses show both ways of the ring at the walk, park gait (flatwalk or intermediate gait), and road gait (running walk or fast rack). Drivers must halt, stand quietly, and rein back. The horse should respond promptly and willingly.

18.2 Tack and Equipment

Complete driving appointments may be found in the NWA Rule Book, Section 10.21. Use of illegal equipment will result in elimination.

18.3 Class Procedure

Horses will enter the ring counterclockwise at the flatwalk (or slow intermediate gait). Competitors will show both ways of the ring at the walk, park gait, and road gait, reversing across the diagonal and to the inside of entries on the rail. Individual workouts may be required of all or selected entrants at discretion of judge. During individual workouts all entrants will be excused from the ring, with only one exhibitor at a time performing in the ring.

Additional Tests may include:

- Pivot with one wheel in place, left or right, at 90 degrees or 180 degrees at judge's discretion.
- Backing 4 to 8 steps and returning to place in line.
- Perform a circle or a figure eight (crossing the center line twice), evaluating consistency of speed, willingness, and flexing of the horse on the turns.
- Turns - within a 30 foot parallel, right and left, evaluating willingness, speed, smoothness.
- Mounting - the driver can mount the cart either by the step-on or slide-on method, being sure that control of the horse is always maintained. The ring master will serve as header.
- Perform at any gait requested by the judge.
- Negotiate a simple obstacle such as driving or backing between 2 markers or poles.

18.4 Scoring

To be judged 75% on handling of reins and whip, control, posture, technique, and ability of driver and 25% on condition and fit of harness and horse, proper harnessing and hitching, and neatness of attire.

When the driver is driving, both feet should be resting on the stirrups or flat on the floor. The back should be straight, hands held forward no more than chest high, with elbows in a slightly cocked position. The driver should be driving on contact at all times. Reins may be held in one or two hands.

18.5 Disqualifications

- Unsafe equipment
- Unruly behavior of the horse or driver
- Excessive use of the whip

19 TRAIL OBSTACLE

19.1 General

The trail horse is required to work over and through obstacles which might be found during a normal day on the range or trail ride.

A good trail horse gives the impression of being a pleasure to ride out and negotiate any obstacle on a trail ride. It can maneuver through a course of obstacles quietly, obediently, with physical skill and a good attitude. It should travel through and between obstacles in a forward manner without compromising its calm, relaxed attitude and way of going. It should approach each obstacle with authority, yet maintaining its willingness to obey the rider with no apparent resistance. Ultimately, the trail horse is skillful, confident, and leaves one with the impression of being sane, safe, sure and a pleasure to ride over any piece of ground for a trail ride.

19.2 Class Specifications

- Exhibitors perform a course over and through obstacles on a reasonably loose rein. Exhibitors are judged on performance and way of going, with emphasis on manners. Exhibitors perform a course over and through at a walk, flat walk or slow gait, running walk or fast gait, canter or lope, depending on the difficulty of the class.
- Rider's hands shall be clear of horse
- Competitors may use English or Western tack and attire but not a combination of both. For complete descriptions of Western tack and attire, please refer to the NWHHA Rule Book Section 8, Attire and Equipment.
- Exhibitors are penalized for any unnecessary delay while approaching obstacle. If a horse takes excessive time at an obstacle, the judges are encouraged to advance it on to next obstacle.
- Obvious unsoundness must be disqualified with no prize awarded.
- No time outs will be allowed.
- In western attire, the exhibitor must hold reins in one hand except for junior horses ridden in a snaffle bit or hackamore with two hands. Hand may not be changed except:
 - putting on or removing a slicker
 - carrying an object from one part of the arena to another
 - working the gate
- The course will include a minimum of six and a maximum of ten obstacles.
- If at any time a trail obstacle is found to be unsafe, it shall be repaired or removed from the course. If it cannot be repaired and horses have completed the course, the score for that obstacle shall be deducted. No horse shall be asked to repeat the course.
- Show managers may elect to offer variations of the trail class, including green, advanced, in-hand, etc. Green classes are limited to horses in their first or second year of showing at trail obstacle. Show managers may elect to allow green horses to cross-enter both green and advanced classes.

19.3 Course Design

Trail obstacles should be designed with safety in mind to prevent accidents and injury. If there is spacing between obstacles, it should allow exhibitors to flatwalk at least 30 feet or lope at least 50 feet. If the horse performs the trail walk between obstacles, there is not a minimum distance between them. The course must consist of at least six obstacles. All obstacles should be safe and in good condition. Courses should be a resemblance to obstacles and occurrences which actually may occur on the trail.

19.3.1 Inspection of the course

- Exhibitors will be allowed to walk and inspect the course (without horse) prior to the start of the class.
- Exhibitors shall alert show management or the judge prior to the beginning of the class if they find any unsafe obstacle.
- No horse may enter the trail course area until the course and the judge are ready.

The judge must walk the course and has the right and duty to alter the course in any manner. The judge may remove or change any obstacle he deems unsafe or non-negotiable. If at any time a trail obstacle is deemed to be unsafe by the judge, it shall be repaired or removed from the course. If it cannot be repaired and horses have completed the course, the score from that obstacle shall be deducted from all previous works for that class.

19.3.2 Jump Standards

All elevated walk-over or low jump poles must be set in a standard jump cup or similar type bracket. The judge has the right to alter the course.

Suggested dimensions of trail obstacles:

- **WALK OVERS** - Minimum height 4"; Maximum height 12". Spacing between logs or poles:
 - Walk over: 22" - 26"
 - Elevated walk over: 22"
 - Lope-over: 7'-8'
- **BACK THROUGH**S - May be on the ground, elevated, or the use barrels. The backthrough chute must have a minimum width of 30 inches. Required turns (like backing through an "L") will require a wider distance between the sides.
- **GATE** Approximately 60" high with latch available at that height.
- Any other maneuvers should figure horse's total length at about eight feet from nose to tail.

19.3.3 Mandatory Obstacles

- Navigate through a safe gate. Gates may be a regular gate or a rope gate
- Ride over at least four (4) logs or poles. May be in a straight line, zigzag, curved, or raised
- Back through and/or around at least 3 markers such as barrels, poles or cones. Backthroughs can be L, V, U, straight or similar shaped courses.

19.3.4 Other ideas for Obstacles

- Groups of logs and brush put together to make it a pile and horse must walk through;
- Backing around barrels or through poles on the ground;
- A line where the horse has to weave through like pole bending with the trees close together;
- Walking forward on the bridge, backing down the bridge;
- Box of poles where a turn on the haunches must be completed inside the box;
- Dismount, ground tie, walk around the horse, come back;

- Sidepass a pole: may be elevated to 12" maximum, but may not have uprights on either side;
- Carrying objects;
- Put on and remove slicker;
- Remove and replace materials from mailbox;
- Any other safe and negotiable obstacle which should reasonably be encountered on a trail ride and meets the approval of the judge;
- A combination of two or more of any obstacle is acceptable;
- Bridges. Bridge must be a min. of 36" wide and at least 6 feet long. Bridge should be sturdy, safe and negotiated at a walk only;
- Tarps, provided that they are secured by poles, flower boxes, etc so that they will not blow or drag;

Obstacles not listed may be used as long as they are not prohibited and may reasonably be expected to be encountered on a trail work.

19.3.5 Prohibited Obstacles

- Animals
- Flames, noise, dry ice, fire extinguisher
- Hides
- Jumps or poles over 12"
- Rocking/moving bridges
- Tires
- Water box with moving or floating object
- Logs or poles elevated in a manner that permits them to roll

(19.4 JUDGING)

19.4.1 Penalties

Minor Faults

- Ticks/rubs on obstacle
- Chewing on bit
- Tail wringing
- Too fast/slow

Major Faults

- Falling/stepping off bridge
- Knocking over markers
- Losing the gate
- Breaking gait
- Refusals. A refusal is any action taken by the horse to avoid performing an obstacle, part of a combination of obstacles or portion of a trail course.
- Stepping outside markers during turns, side passes or backing
- Wrong lead, corrected prior to completion of the lope

19.4.2 No Score on an Obstacle

- Working an obstacle differently than noted on the pattern
- Attempting, but not completing an obstacle
- Not in the posted gait or correct lead
- Third refusal

19.4.3 Disqualification

- Not working obstacles in posted order (“off course”)*.
- More than one finger between reins, except when changing hands to work an obstacle.
- Major disobedience - rearing, schooling
- Touching in front of cinch
- Fall of horse or rider
- Illegal equipment
- Abuse of horse
- In western tack, use of two hands or changing hands on reins except where permitted as described above (except for junior horses ridden with snaffle bits or bosals)
- Equipment failure that delays competition of pattern
- Riding outside designated boundary marker of the course

* Off Course is defined as not following the drawn pattern by taking an obstacle in the wrong direction, wrong side, or wrong sequence, or skipping an obstacle unless directed by the judge.

19.5 SCORING

Scoring will be on the basis of zero to infinity, with 70 denoting an average performance. Each obstacle will receive an obstacle score and may also be subject to a penalty.

Each obstacle will be scored as follows:

- -1 ½ extremely poor,
- -1 very poor,
- -½ poor,
- 0 correct,
- +½ good,
- +1 very good,
- + 1 ½ excellent.

Obstacle scores are to be determined and assessed independently of penalty points.

Should a tie occur after all contestants have performed, two methods may be used to break the tie.

- An over-all attitude, manners, and style score may be used as a tie-breaker.
- In addition to the obstacle scoring, scored gaits can also be useful in placing a class.

19.5.1 Penalties

½ Point

- Each tick of log, pole, cone or obstacle

1 Point

- Each hit of or stepping on log, pole, cone or obstacle
- Break of gait at walk, flat walk, running walk or canter/lope for two strides or less
- Skipping over or failing to step into required space
- Split pole in canter/lope over

3 Points

- Break of gait for more than 2 strides
- Out of lead or break of gait at canter/lope (except when correcting an incorrect lead)
- Knocking down an elevated pole, cone, barrel, plant obstacle or severely disturbing an obstacle
- Stepping outside the confines of, falling or jumping off or out of an obstacle with one foot.

5 Points

- Dropping object required to be carried on course
- First refusal, balk, or attempting to evade an obstacle by shying or backing more than 2 strides away
- Letting go of gate or dropping rope gate
- Use of either hand to instill fear or praise
- Stepping outside the confines of, falling or jumping off or out of an obstacle with more than one foot
- Blatant disobedience (kicking out, bucking, rearing, striking)
- Second refusal, balk or attempting to evade an obstacle by shying or backing more than two strides away

20 WATER GLASS

In water glass, each contestant rides their mount while carrying a cup full of water. Contestants perform at the discretion of the judge. The rider who has the most water at the end wins.

20.1 Tack and Equipment

Either English or western tack is appropriate for this class. Refer to the NWA Rule book, section 8 for more information on acceptable equipment. Martingales, tie-downs, and boots of any kind are not allowed in water glass.

20.2 General Rules

Exhibitors will enter the ring and will receive a glass of water. Glasses must not exceed five (5) inches tall. Water may be “topped off” after the rider receives the glass, but before the class begins. Exhibitors will ride to the rail and perform at the discretion of the judge. The judge may ask for the walk, flatwalk, running walk, halt, back, and turns. The judge may ask for the canter in the event of a tie.

A noted change of gaits is required when the flatwalk and running walk are called or the Judge will disqualify exhibitor. The Judge may also call for the extending of the arm holding the water out to the side, above the exhibitor’s eye level or above the shoulder. The Judge may also call for switching hands. Small circles either in the flatwalk or running walk or other patterns may be called. A trail walk may be called or other maneuvers such as backing up, turn on the forehand or turn on the haunches. The judge may request that exhibitors drop their stirrups.

When exhibitors are called to the lineup, they will relinquish their cups to the judge or his(her) designee for judging.

20.3 Scoring

Glasses may be weighed, measured with a ruler, or measured by eye. Generally, weight is the most accurate determination. Other measurements often result in ride-offs. The rider with the most water in their glass wins, and the next most second, etc. In case of a tie at any placing, the judge may call for a ride-off. In this case, the same glasses are returned to the exhibitors who will ride off, and they continue with the amount of water that they had prior to judging.

20.4 Disqualification

1. Hand or fingers may not cover the top of the glass at any time.
2. Failure to canter when called.
3. Failure to change gait when called.
4. Standing in the stirrups with the seat clear of the saddle.

21 WESTERN RIDING

21.1 General

In Western Riding, the horse exhibits responsive lead changes at the lope, manners, and a confident disposition. Emphasis is placed on smoothness and the horse’s ability to change leads precisely. The horse should have a relaxed appearance. The horse should cross the log without breaking gait or radically changing stride. One of four patterns shall be performed.

On the pattern:

- Markers should be separated by at least 30 feet (9 meters) but not more than 50 feet (15 meters) on the sides with 5 markers.
- Markers must be a minimum of 15 feet from the fence and with 50 to 80 foot width in the pattern, as the arena permits.
- A solid log or pole should be used and be a minimum of 8 feet in length.

21.2 Tack and Equipment

Western tack and attire are required. Properly worn ASTM/SEI approved headgear is recommended for the exhibitor in any and all events and shall not be penalized.

For complete descriptions of Western tack and attire, please refer to the NWA Rules Rule Book Section 8 Attire and Equipment and the NWA Rules and Regulations for Versatility Events Section 17.2.

Protective boots and polo wraps are permitted in Western Riding.

21.3 Scoring

Exhibitors shall be scored on a basis of 0-100 with 70 denoting an average performance. Points will be added or subtracted from the maneuvers as follows:

- -1.5 extremely poor,
- -1 very poor,
- -.5 poor,
- 0 average,
- +.5 good,
- +1 very good,
- +1.5 excellent.

Maneuver scores are to be determined independently of penalty points.

The following characteristics are considered faults and should be judged accordingly in maneuver scores:

- Opening mouth excessively
- Anticipating signals
- Stumbling

Credits

- Changes of leads, hind and front simultaneously
- Change of lead near the center point of the lead change area
- Accurate and smooth pattern
- Even pace throughout
- Easy to guide and control with rein and leg
- Manners and disposition

Penalty Points

A contestant shall be penalized each time the following occur:

Five (5) points

- Wrong lead beyond the next designated change area (failure to change leads includes cross-cantering). Each failure to change results in an additional five-point penalty.
- Kicking out, biting and bucking

Three (3) points

- Not performing the specific gait or stopping when called for within 10 feet of the designated area.
- Simple change of leads
- Additional lead changes anywhere in pattern (except when correcting an extra change or incorrect lead)
- Break of any gait for more than two strides

One (1) point

- Hitting or rolling log
- Wrong lead more than one stride either side of the center point and between the markers
- Splitting the log (log between the two front or two hind feet) at the lope

One-half (1/2) point

- Tick or light touch of log
- Lead change not synchronous (Front to hind or hind to front)

21.4 Disqualification

- Illegal equipment
- Willful abuse
- Off course
- Knocking over markers
- Missing log
- Major refusal
- Major disobedience - rearing, etc.

21.5 Accepted Patterns

*Reproduced with permission of the American Quarter Horse Association (See Western Riding Patterns I, II, III and IV on pages 52-55)

WESTERN RIDING PATTERN I

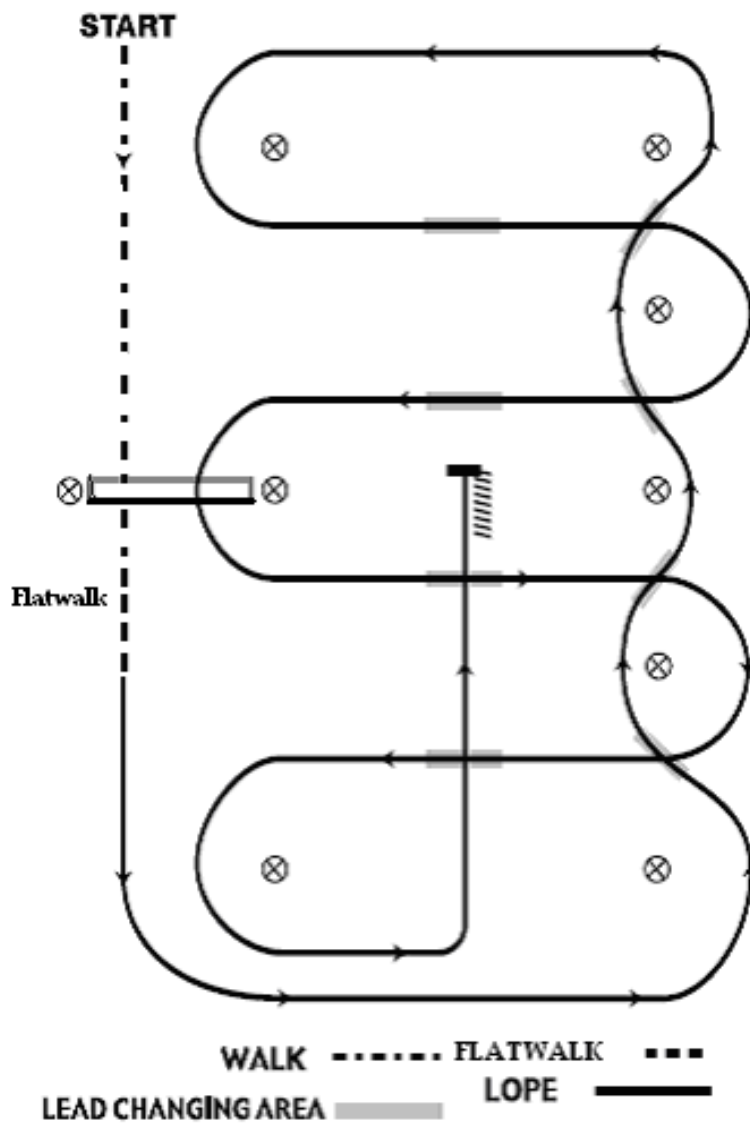

1. Walk at least 15' & walk over log, transition to flat walk
2. Transition to left lead & lope around end
3. First line change
4. Second line change
5. Third line change
6. Fourth line change lope around the end of arena
7. First crossing change
8. Second crossing change
9. Lope over log
10. Third crossing change
11. Fourth crossing change
12. Lope up the center, stop & back

WESTERN RIDING PATTERN 2

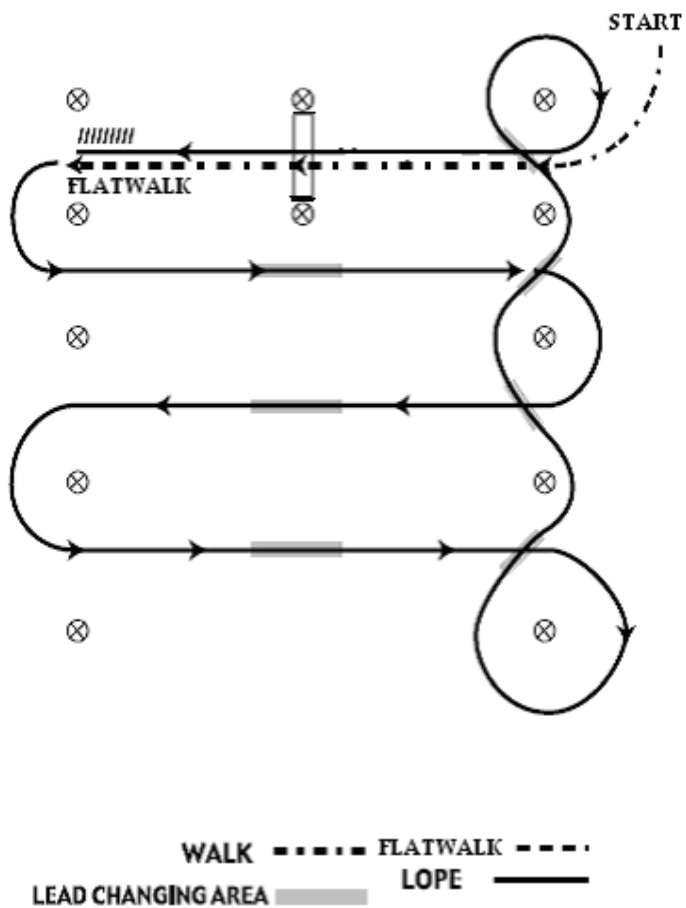

1. Walk over log, transition to flat walk
2. Transition to the lope, on the left lead
3. First crossing change
4. Second crossing change
5. Third crossing change
6. Circle & first line change
7. Second line change
8. Third line change
9. Fourth line change & circle
10. Lope over log
11. Lope, stop & back

WESTERN RIDING PATTERN III

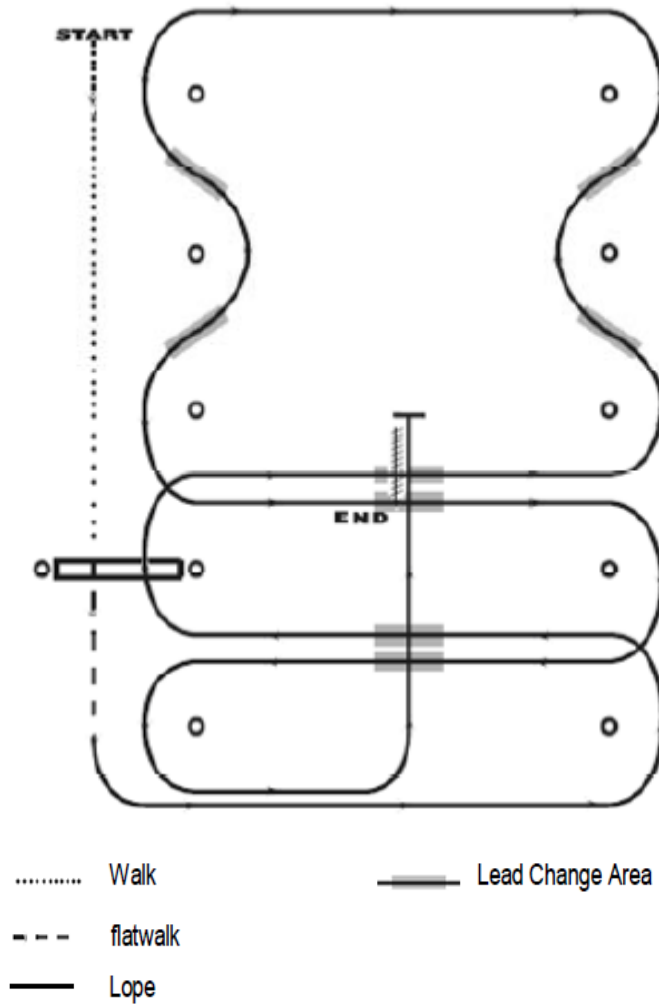

1. Walk over log, transition to flat walk
2. Transition to the lope, on the left lead
3. First crossing change
4. Lope over log
5. Second crossing change
6. First line change
7. Second line change
8. Third line change
9. Fourth line change
10. Third crossing change
11. Fourth crossing change
12. Lope up the center, stop & back

WESTERN RIDING PATTERN IV

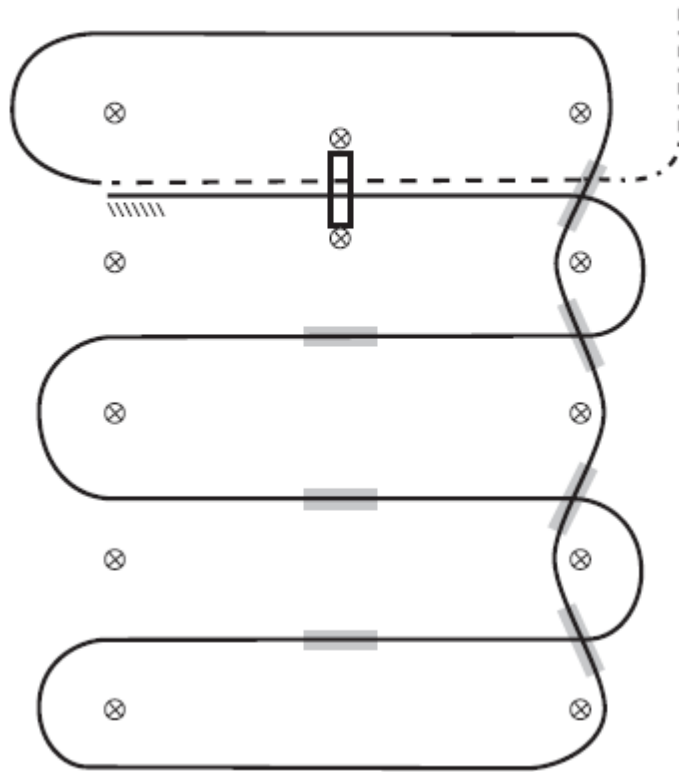

..... Walk

————— Lead Change Area

- - - flatwalk

————— Lope

1. Walk over log, transition to flatwalk
2. Transition to the lope, on the right lead
3. First line change
4. Second line change
5. Third line change
6. Fourth line change
7. First crossing change
8. Second crossing change
9. Third crossing change
10. Lope over log
11. Lope, Stop & back

21.6 Judge's Score Card

The following score card may be used by NWA judges to assess competitors in the western riding classes:

WESTERN RIDING SCORE SHEET Judge _____ Date _____

Maneuver Scores: +1½ Excellent, +1 Very Good, +½ Good, 0 Average, -½ Poor, -1 Very Poor, -1½ Extremely Poor

Penalty ½: Tick or light touch of log; hind legs skipping or coming together during lead change; non-simultaneous lead change

Penalty 1: Hit or rolling log; out of lead more than one stride either side of the center point & between the markers; splitting the log(log between the 2 front or 2 hind feet at the lope; break of gait at the walk or jog up to 2 strides

Penalty 3: Not performing the specific gait or stopping when called for in the pattern; simple change of leads; out of lead at or before the marker prior to the designated change area or out of lead at or after the marker after the designated change area; additional lead changes anywhere in pattern; in pattern 1 & 3 failure to start the lope within 30 ft. after crossing the log at the jog; break of gait at walk or jog for more than 2 strides; break of gait at the lope

Penalty 5: Out of lead beyond the next designated change area; blatant disobedience including kicking out, biting, bucking and rearing

Penalty Score 0: Illegal equipment; willful abuse; off course; knocking over markers; completely missing log; major refusal; major disobedience or schooling; failure to start lope prior to end cone in patterns 1 & 3; 4 or more simple lead changes &/or failure to change leads; overturn of more than ¼ turn; head consistently carried too low consistently; over flexed, except in novice classes

W/O	Entry No.	Maneuver Description	1	2	3	4	5	6	7	8	9	10	11	12	Penalty Total	FINAL SCORE
		Penalty														
		Maneuver Score														

		Penalty														
		Maneuver Score														

REFERENCES

1. Official Handbook of the American Quarter Horse Association, www.aqha.com
2. National Reining Horse Patterns, <http://www.nrha.com>
3. USEF Rules and Governance, Rule Book, United States Equestrian Federation, www.usef.org